

**AGENDA**  
**COUNCIL WORKSHOP**  
**February 1, 2018**  
**5:30 P.M.**

- (1) Review council meeting agenda.
- (2) Discussion on Capital Projects for Fiscal Year 2018-2019.

**AGENDA**  
**CITY COUNCIL MEETING**  
**February 1, 2018**  
**6:30 P.M.**

1. Call to Order.
2. Pledge of Allegiance.
3. Roll Call.
4. Mayor's Correspondence:
5. Citizen's Request.
6. Consent Agenda.
  - Minutes of the regular City Council meeting of January 18, 2018;
  - Minutes of the Safety Committee meeting of January 23, 2018;
  - Receive Council Reports;
  - Appointment of Daniel Winn to the Historic Preservation Commission, term to expire September 19, 2019;
  - Appointment of Michael Greenwald to the Historic Preservation Commission, term to expire September 19, 2019;
  - Sidewalk Display Permit – Kandie White, 822 Main Street;
  - Resolution approving a Urban Revitalization Tax Exemption for the following home owners: Steve & Orma Andrews, 1710 Park St., partial basement, kitchen and breezeway addition and interior remodel;
  - Aaron & Tammy Smith, 524 Hawthorne St., addition and detached garage; Nancy Meinhardt, 2945 Middle Road, single family dwelling;
  - Motion to pay the bills and transfers listed within Register No.'s 4977-4979;
7. (a) Public hearing on a proposal to vacate and dispose of a 20' x 300' improved alleyway in Block 41 of Reid's addition, City of Keokuk, Lee County, Iowa.  
  
(b) Consider resolution on a proposal to vacate and dispose of a 20' x 300' improved alleyway in Block 41 of Reid's addition, City of Keokuk, Lee County, Iowa.
8. Consider resolution approving the third and final reading of Ordinance No. 1979 Rezoning Lots 1 through 6, Block 41, Reid's Addition; Lots 1 & 2 from R-2, single family dwelling district to M-2, Heavy Industrial District and Lots 3, 4, 5 & 6 from R-3 two family dwelling to M-2, Heavy Industrial District.
9. Consider resolution approving the third and final reading of Ordinance No. 1980 amending the code of ordinances of the City of Keokuk to repeal Chapter 2.50 and 2.16, and to adopt Chapter 1.15 regarding the method of City Elections.
10. Consider resolution approving the initial reading of Ordinance No. 1981 amending Title 13 Chapter 8, "Sewer Rates", of the Keokuk Municipal Code.
11. Motion to approve the replacement of Cage Drive unit from WesTech for the Water Pollution Control Plant at a cost of \$ 42,043.00.

12. Motion to award \$ 5,000.00 to the America's First Great Dam Foundation for a virtual reality tour project.
13. Consider resolution authorizing the disposal of surplus City property in the form of a 2000 Pierce Saber Rescue Pumper.
14. Committee Reports (Reports from council representatives).
15. New Business:
16. Adjourn meeting.

**MINUTES**  
**CITY COUNCIL MEETING**  
**January 18, 2018**  
**6:30 P.M.**

The City Council of the City of Keokuk met in regular session on January 18, 2018 at 6:30 p.m. in the City Council Chambers, 415 Blondeau Street, with Mayor Thomas L. Richardson presiding and six council members present, three absent: Ron Payne, Devon Dade, John Helenthal, Larry Mortimer, Michael Greenwald and Roger Bryant. Mike O'Connor, Mike Moore and Susan Dunek were absent. Staff in attendance: City Administrator Aaron Burnett, City Clerk Jean Ludwig, Public Works Director Mark Boussetot, Police Chief Dave Hinton.

Motion made by Helenthal, Second by Payne to approve the agenda including the consent agenda. (6) AYES, (0) NAYS. Motion carried.

- Minutes of the regular City Council meeting of January 4, 2018;
- Receive Council Reports;
- Appointment of Angela Profeta to the Keokuk Barge Commission, term to expire January 1, 2021;
- Appointment of Ryan Uhlmeier to the Keokuk Barge Commission, term to expire January 1, 2022;
- Sidewalk Display Permit – Joystick, 714 Main Street;
- Motion to pay the bills and transfers listed within Register No.'s 4974-4976;

Motion made by Payne, Second by Bryant to approve the following proposed **RESOLUTION NO. 6-18**: “A RESOLUTION APPROVING THE SECOND READING OF **ORDINANCE NO. 1979** REZONING LOTS 1 THROUGH 6, BLOCK 41, REID’S ADDITION; LOTS 1 & 2 FROM R-2, SINGLE FAMILY DWELLING DISTRICT TO M-2, HEAVY INDUSTRIAL DISTRICT AND LOTS 3, 4, 5 & 6 FROM R-3 TWO FAMILY DWELLING TO M-2, HEAVY INDUSTRIAL DISTRICT.”

Roll Call Vote: (6) AYES – Payne, Dade, Helenthal, Mortimer, Greenwald and Bryant. (0) NAYS. Motion carried.

Motion made by Helenthal, Second by Payne to approve the following proposed **RESOLUTION NO. 7-18**: “A RESOLUTION APPROVING THE SECOND READING OF **ORDINANCE NO. 1980** AMENDING THE CODE OF ORDINANCES OF THE CITY OF KEOKUK TO REPEAL CHAPTER 2.50 AND 2.16, AND TO ADOPT CHAPTER 1.5 REGARDING THE METHOD OF CITY ELECTIONS.”

Roll Call Vote: (6) AYES – Payne, Dade, Helenthal, Mortimer, Greenwald and Bryant. (0) NAYS. Motion carried.

Motion made by Helenthal, Second by Dade to amend the resolution title to change the date of the public hearing from February 1, 2018 to February 15, 2018 for disposal of 1113 and 1117 Concert Street. (6) AYES, (0) NAYS. Motion carried.

Motion made by Greenwald, Second by Helenthal to approve the amended **RESOLUTION NO. 8-18** “SETTING A PUBLIC HEARING FOR 6:30 P.M., FEBRUARY 15, 2018 IN THE CITY COUNCIL CHAMBERS, 415 BLONDEAU STREET, FOR DISPOSAL OF 1113 AND 1117 CONCERT STREET.” (6) AYES, (0) NAYS. Motion carried.

Mayor Richardson opened the public hearing at 6:38 p.m. to consider bids received for the replacement of the River Road and Indian Hills Lift Stations. A public notice was published in the Daily Gate City on December 29, 2017.

**COMMENTS:** Public Works Director Busselot explained the upgrades were due. It would add capacity and update pumps and controls. Burnett said two bids were within \$ 442.00. The slightly higher bid is recommended using the local preference option in the purchasing policy to keep more dollars in the community.

Mayor Richardson closed the public hearing at 6:42 p.m. and the following proposed resolution was adopted.

Motion made by Helenthal, Second by Bryant to approve the following proposed **RESOLUTION NO. 9-18:** “A RESOLUTION AUTHORIZING THE MAYOR TO ACCEPT THE BID FROM KEOKUK CONTRACTORS OF KEOKUK, IOWA FOR THE REPLACEMENT OF THE RIVER ROAD AND INDIAN HILLS LIFT STATIONS. (6) AYES, (0) NAYS. Motion carried.

Motion made by Payne, Second by Bryant to approve the following proposed **RESOLUTION NO. 10-18:** “A RESOLUTION TO APPROVE A FIVE YEAR CAPITAL IMPROVEMENT PROGRAM AT THE KEOKUK MUNICIPAL AIRPORT.” Burnett said there is no commitment in passing this resolution. The City is only filing a plan and stating it has merit. If any projects are to be done, they would come before the council for approval. (6) AYES, (0) NAYS. Motion carried.

Motion made by Helenthal, Second by Mortimer to approve the following proposed **RESOLUTION NO. 11-18:** “A RESOLUTION SETTING A PUBLIC HEARING FOR 6:30 P.M. THURSDAY, FEBRUARY 1, 2018 IN THE CITY COUNCIL CHAMBERS, 415 BLONDEAU STREET, ON A PROPOSAL TO VACATE AND DISPOSE OF A 20’ X 300’ IMPROVED ALLEYWAY IN BLOCK 41 OF REID’S ADDITION, CITY OF

KEOKUK, LEE COUNTY, IOWA AND THAT PROPER NOTICES BE PUBLISHED.”  
(6) AYES, (0) NAYS. Motion carried.

**COMMITTEE REPORTS:** Burnett said the Historic Preservation Commission met on January 17<sup>th</sup>. Councilperson Greenwald and former Councilperson Dan Winn have both offered to be on the commission. The commission is hoping to increase grant opportunities and work on the creation of historic districts.

Motion to adjourn the meeting made by Helenthal, Second by Mortimer. (6) AYES, (0) NAYS. Motion carried.

Meeting adjourned at 6:48 p.m.

**CITY OF KEOKUK**  
**SAFETY COMMITTEE MEETING MINUTES**  
**Tuesday, January 23, 2018**  
**8:30AM**

Meeting called to order at 8:35 am.

**In Attendance:** Tom Richardson, John Reiter, Mark Bousset, Aaron Burnett, Jean Ludwig, Dave Johnson, Mark Weirather, Bob Weis, Ed Ketterer.

**Absent:** Roger Bryant, Jason Schmitt

Ludwig read the minutes from the December meeting. Motion to approve the minutes as read by Ketterer, second by Weirather. Motion Approved.

**OLD BUSINESS:**

We have a schedule of training set up for the next four months with SCC. We will have one topic per month for the next four months. Bousset said we can also add special topics if we choose to do so.

Burnett – no update on the silica policy.

Hoop building – no update. Richardson asked what the hoop building was for. It is per an engineer's report to get salt out of the car barn to prevent further damage to the building. A time frame for constructing the building was discussed. All agreed it can be built any time after approval. Johnson asked about leaching problems with the salt. Burnett said we should try to contain it as much as possible.

Respirators have been ordered for Sewer Maintenance Department. When they arrive, we'll proceed with the fit testing.

**NEW BUSINESS:**

No Company Nurse Reports since last meeting.

No near misses reported that need attention.

We received a copy of the mold testing report conducted by ServePro at the bridge building. It said all samples taken were within normal ranges. They made a recommendation regarding removing some construction materials, then cleaning and treating the area.

Weis asked about fixing a chain & hook on a hoist. They use the hoist along with jack stands when maintaining mowers. When it was inspected, a problem was noted with the hook and a welded link. The inspector would not make any recommendations on who could fix it. If repaired, Weis asked if it should be inspected again. Bousset said he would contact Chuck Pietscher to see if he had any recommendations, as he may have knowledge on the subject.

Weis brought up electrical problems in the Park and Cemetery Department buildings. An electrician gave a bid to the Park Manager for the park building. Burnett said he should also give a bid on the Cemetery Building.

Johnson asked about progress on retooling the trash bins. Bousset said 5-7 have been finished.

Johnson asked if safety glasses for employees that wear glasses have been ordered. Bousset said he would contact the supplier.

**SET THE DATE** for the next meeting: February 20, 2018 at 8:30am in Council Chambers.

**MOTION TO ADJOURN** by Marion, second by Ketterer. Meeting adjourned at 8:50 am.  
Submitted by Jean Ludwig, Safety Committee.

**PCT OF FISCAL YTD 58.3%**

| ACCOUNT NUMBER | ACCOUNT TITLE                  | TOTAL<br>BUDGET     | PTD<br>BALANCE    | YTD<br>BALANCE      | PERCENT<br>EXPENDED | UNEXPENDED          |
|----------------|--------------------------------|---------------------|-------------------|---------------------|---------------------|---------------------|
|                | POLICE ADMINISTRATION TOTAL    | 1,346,731.00        | 74,197.11         | 692,747.48          | 51.44               | 653,983.52          |
|                | POLICE UNION TOTAL             | 1,097,766.00        | 91,064.51         | 623,026.80          | 56.75               | 474,739.20          |
|                | POLICE COMMUNICATIONS TOTAL    | 56,131.00           | 4,418.39          | 31,875.36           | 56.79               | 24,255.64           |
|                | POLICE RECORDS TOTAL           | 101,381.00          | 8,079.34          | 57,688.02           | 56.90               | 43,692.98           |
|                | LEE CO NAR TASK FORCE TOTAL    | 87,627.00           | 7,559.06          | 53,650.46           | 61.23               | 33,976.54           |
|                | GTSB SAFETY GRANT TOTAL        | 5,058.00            | .00               | 849.86              | 16.80               | 4,208.14            |
|                | COPS IN SCHOOLS TOTAL          | .00                 | .00               | .00                 | .00                 | .00                 |
|                | FLOOD CONTROL TOTAL            | 31,450.00           | 332.20            | 8,042.37            | 25.57               | 23,407.63           |
|                | FIRE ADMINISTRATION TOTAL      | 1,051,453.00        | 241,504.86        | 778,713.97          | 74.06               | 272,739.03          |
|                | FIRE PROTECTION TOTAL          | 1,350,080.00        | 104,617.11        | 772,015.71          | 57.18               | 578,064.29          |
|                | EMERGENCY CORP TOTAL           | 6,225.00            | 474.57            | 7,205.84            | 115.76              | 980.84-             |
|                | FIRE EQUIPMENT RESERVE TOTAL   | .00                 | .00               | .00                 | .00                 | .00                 |
|                | FIRE TRAINING GRANT TOTAL      | .00                 | .00               | .00                 | .00                 | .00                 |
|                | EMERGENCY CORP TOTAL           | .00                 | .00               | .00                 | .00                 | .00                 |
|                | HOUSING TOTAL                  | 611,440.00          | 228,997.20        | 419,455.63          | 68.60               | 191,984.37          |
|                | ANIMAL CONTROL TOTAL           | 129,938.00          | 6,922.08          | 64,482.91           | 49.63               | 65,455.09           |
|                | <b>PUBLIC SAFETY TOTAL</b>     | <b>5,875,280.00</b> | <b>768,166.43</b> | <b>3,509,754.41</b> | <b>59.74</b>        | <b>2,365,525.59</b> |
|                | STREETS/ROADWAYS TOTAL         | .00                 | .00               | .00                 | .00                 | .00                 |
|                | ROADWAY MAINTENANCE/RUT TOTAL  | 670,712.00          | 30,932.04         | 348,147.39          | 51.91               | 322,564.61          |
|                | STREET LIGHTING TOTAL          | 217,000.00          | 591.01            | 71,307.53           | 32.86               | 145,692.47          |
|                | TRAFFIC LIGHTS TOTAL           | 28,000.00           | 2,625.13          | 99,369.64           | 354.89              | 71,369.64-          |
|                | SNOW REMOVAL TOTAL             | 92,770.00           | 16,017.94         | 17,096.11           | 18.43               | 75,673.89           |
|                | STREET CLEANING TOTAL          | 38,920.00           | .00               | 16,261.64           | 41.78               | 22,658.36           |
|                | AIRPORT TOTAL                  | 100,463.00          | 3,195.98          | 48,486.47           | 48.26               | 51,976.53           |
|                | BULK FUEL TOTAL                | 79,950.00           | 38.09             | 37,341.39           | 46.71               | 42,608.61           |
|                | VEHICLE MAINTENANCE TOTAL      | 234,804.00          | 15,350.10         | 128,153.21          | 54.58               | 106,650.79          |
|                | GENERAL MAINTENANCE TOTAL      | .00                 | .00               | .00                 | .00                 | .00                 |
|                | PUBLIC WORKS EQUIP RES TOTAL   | .00                 | .00               | .00                 | .00                 | .00                 |
|                | <b>PUBLIC WORKS TOTAL</b>      | <b>1,462,619.00</b> | <b>68,750.29</b>  | <b>766,163.38</b>   | <b>52.38</b>        | <b>696,455.62</b>   |
|                | LIBRARY TOTAL                  | 522,751.00          | 32,040.24         | 264,049.42          | 50.51               | 258,701.58          |
|                | LIBRARY COUNTY TOTAL           | 8,817.00            | 53.26             | 53.26               | .60                 | 8,763.74            |
|                | LIBRARY GRANTS TOTAL           | .00                 | .00               | .00                 | .00                 | .00                 |
|                | LIBRARY TRUST FUND TOTAL       | .00                 | .00               | 198.15              | .00                 | 198.15-             |
|                | RIVER MUSEUM TOTAL             | 13,938.00           | 111.19            | 9,138.24            | 65.56               | 4,799.76            |
|                | GRAND THEATRE TOTAL            | 84,350.00           | 1,547.24          | 41,184.76           | 48.83               | 43,165.24           |
|                | GRAND THEATRE RESERVE TOTAL    | .00                 | .00               | .00                 | .00                 | .00                 |
|                | UNION DEPOT TOTAL              | 7,900.00            | 507.78            | 2,366.16            | 29.95               | 5,533.84            |
|                | HISTORIC PRESERVATION COM TOTA | .00                 | .00               | .00                 | .00                 | .00                 |
|                | PARKS TOTAL                    | 316,572.00          | 29,653.49         | 373,248.58          | 117.90              | 56,676.58-          |
|                | MARY E TOLMIE FUND TOTAL       | .00                 | .00               | .00                 | .00                 | .00                 |
|                | PARK MAINT & IMPROV RESER TOTA | .00                 | .00               | .00                 | .00                 | .00                 |
|                | JOYCE PARK TOTAL               | .00                 | .00               | .00                 | .00                 | .00                 |
|                | SWIMMING POOL TOTAL            | 130,529.00          | 279.62            | 68,792.68           | 52.70               | 61,736.32           |
|                | RED CROSS TOTAL                | .00                 | .00               | .00                 | .00                 | .00                 |
|                | SWIMMING POOL RESERVE TOTAL    | .00                 | .00               | .00                 | .00                 | .00                 |

**BUDGET REPORT**  
**CALENDAR 1/2018, FISCAL 7/2018**

**PCT OF FISCAL YTD 58.3%**

| ACCOUNT NUMBER | ACCOUNT TITLE                   | TOTAL<br>BUDGET | PTD<br>BALANCE | YTD<br>BALANCE | PERCENT<br>EXPENDED | UNEXPENDED  |
|----------------|---------------------------------|-----------------|----------------|----------------|---------------------|-------------|
|                | CEMETERY TOTAL                  | 290,498.00      | 15,201.40      | 121,603.38     | 41.86               | 168,894.62  |
|                | PERPETUAL CARE TOTAL            | .00             | .00            | .00            | .00                 | .00         |
|                | HOTEL/MOTEL TAX TOTAL           | 210,000.00      | .00            | 378,140.67     | 180.07              | 168,140.67- |
|                |                                 | -----           | -----          | -----          | -----               | -----       |
|                | CULTURE & RECREATION TOTAL      | 1,585,355.00    | 79,394.22      | 1,258,775.30   | 79.40               | 326,579.70  |
|                |                                 |                 |                |                |                     |             |
|                | RBEG GRANT TOTAL                | .00             | .00            | 136.28         | .00                 | 136.28-     |
|                | HOUSING & URBAN RENEWAL TOTAL   | .00             | 93.95          | 2,429.52       | .00                 | 2,429.52-   |
|                | GENERAL ECONOMIC DEVELOP TOTA   | .00             | .00            | 225,959.00     | .00                 | 225,959.00- |
|                | LHAP GRANT TOTAL                | .00             | .00            | .00            | .00                 | .00         |
|                | TARGETED JOBS TAX CREDIT TOTA   | .00             | 95,715.05      | 270,492.73     | .00                 | 270,492.73- |
|                | IFA PROJECT-BASED HOUSING TOTA  | .00             | .00            | .00            | .00                 | .00         |
|                | LOW & MODERATE INCOME TOTAL     | .00             | .00            | .00            | .00                 | .00         |
|                | BUILDING/ZONING TOTAL           | 163,495.00      | 9,068.54       | 73,352.21      | 44.87               | 90,142.79   |
|                | FERRO-SIL BUILDING TOTAL        | 2,550.00        | 11,645.52      | 79,263.63      | 3,108.38            | 76,713.63-  |
|                |                                 | -----           | -----          | -----          | -----               | -----       |
|                | COMMUNITY & ECONOMIC DEV TOTA   | 166,045.00      | 116,523.06     | 651,633.37     | 392.44              | 485,588.37- |
|                |                                 |                 |                |                |                     |             |
|                | MAYOR, COUNCIL, CLERK ADM TOTA  | 609,164.00      | 39,931.60      | 354,837.74     | 58.25               | 254,326.26  |
|                | DATA PROCESSING TOTAL           | 19,500.00       | .00            | 12,208.50      | 62.61               | 7,291.50    |
|                | PUBLIC WORKS ADMINISTRA TOTAL   | 349,842.00      | 24,277.82      | 206,328.57     | 58.98               | 143,513.43  |
|                | CONTINGENCY TOTAL               | .00             | .00            | .00            | .00                 | .00         |
|                | ELECTIONS TOTAL                 | 12,000.00       | 2,553.41       | 9,691.33       | 80.76               | 2,308.67    |
|                | CITY ATTORNEY TOTAL             | 5,000.00        | 4,420.00       | 20,860.00      | 417.20              | 15,860.00-  |
|                | MUNICIPAL BUILDING TOTAL        | 165,300.00      | 1,676.21       | 25,483.79      | 15.42               | 139,816.21  |
|                | GENERAL INSURANCE TOTAL         | 125,000.00      | .00            | 5,358.00       | 4.29                | 119,642.00  |
|                | 10% SALES TAX/HUMAN DEVEL TOTA  | .00             | .00            | .00            | .00                 | .00         |
|                | PUBLIC SERVICE TV TOTAL         | 1,659.00        | .00            | 398.94         | 24.05               | 1,260.06    |
|                |                                 | -----           | -----          | -----          | -----               | -----       |
|                | GENERAL GOVERNMENT TOTAL        | 1,287,465.00    | 72,859.04      | 635,166.87     | 49.33               | 652,298.13  |
|                |                                 |                 |                |                |                     |             |
|                | DEBT SERV/2016B TOTAL           | 403,740.00      | .00            | 44,620.00      | 11.05               | 359,120.00  |
|                | DEBT SERVICE TOTAL              | 318,000.00      | .00            | .00            | .00                 | 318,000.00  |
|                | DEBT SERVICE-2009A SEWER TOTA   | .00             | .00            | 250.00         | .00                 | 250.00-     |
|                | DEBT SERVICE-13D Grand Av TOTA  | 268,100.00      | .00            | 34,300.00      | 12.79               | 233,800.00  |
|                | DEBT SERVICE -12 GO BONDS TOTA  | 100,024.00      | .00            | 12,761.25      | 12.76               | 87,262.75   |
|                | DEBT SERVICE-2013B Refi 06 TOTA | 232,935.00      | .00            | 16,717.50      | 7.18                | 216,217.50  |
|                | DEBT SERVICE-HAMPTON INN TOTA   | .00             | .00            | .00            | .00                 | .00         |
|                | DEBT SERVICE-2013A Fire E TOTA  | .00             | .00            | .00            | .00                 | .00         |
|                | DEBT SERVICE-09 GO BONDS TOTA   | .00             | .00            | 250.00         | .00                 | 250.00-     |
|                | DEBT SERVICE-2013C Aquati TOTA  | 284,875.00      | .00            | 17,687.50      | 6.21                | 267,187.50  |
|                | DEBT SERV/2009D/2010 TOTAL      | .00             | .00            | .00            | .00                 | .00         |
|                | DEBT SERV/2016A TOTAL           | 295,922.00      | .00            | 30,711.25      | 10.38               | 265,210.75  |
|                | Floodwall TIF TOTAL             | .00             | .00            | .00            | .00                 | .00         |
|                | River Hills TIF TOTAL           | .00             | .00            | .00            | .00                 | .00         |
|                | KEO SENIOR HOUSING TIF TOTAL    | .00             | .00            | .00            | .00                 | .00         |
|                | TWIN RIVERS TIF TOTAL           | .00             | .00            | .00            | .00                 | .00         |
|                | HAMPTON INN TIF TOTAL           | .00             | .00            | .00            | .00                 | .00         |

**PCT OF FISCAL YTD 58.3%**

| ACCOUNT NUMBER | ACCOUNT TITLE                  | TOTAL<br>BUDGET | PTD<br>BALANCE | YTD<br>BALANCE | PERCENT<br>EXPENDED | UNEXPENDED    |
|----------------|--------------------------------|-----------------|----------------|----------------|---------------------|---------------|
|                | DOWNTOWN URBAN RENEW TIF TOTA  | .00             | .00            | 16,741.00      | .00                 | 16,741.00-    |
|                | DEBT SERVICE TOTAL             | 1,903,596.00    | .00            | 174,038.50     | 9.14                | 1,729,557.50  |
|                | FLOODWALL REPAIR PROJECT TOTA  | .00             | .00            | .00            | .00                 | .00           |
|                | RIVERFRONT BARGE PROJECT TOTA  | .00             | 7,304.61       | 7,304.61       | .00                 | 7,304.61-     |
|                | 02 SIDEWALK PROGRAM TOTAL      | .00             | .00            | 2,975.13       | .00                 | 2,975.13-     |
|                | 04 CURB & GUTTER TOTAL         | .00             | .00            | .00            | .00                 | .00           |
|                | 03 ACCESS IMPROV/ADA TOTAL     | .00             | .00            | .00            | .00                 | .00           |
|                | GRAND AVE STREET PROJECT TOTA  | .00             | .00            | 4,763.56       | .00                 | 4,763.56-     |
|                | 12 YEAR STREET PROGRAM TOTAL   | 500,000.00      | 3,525.11       | 573,237.10     | 114.65              | 73,237.10-    |
|                | TOTAL                          | .00             | .00            | .00            | .00                 | .00           |
|                | AIRPORT REHAB TOTAL            | .00             | .00            | .00            | .00                 | .00           |
|                | AIRPORT-FFA #18 RUNWAY TOTAL   | .00             | .00            | .00            | .00                 | .00           |
|                | AIRPORT-RUNWAY GRANT #17 TOTA  | .00             | .00            | .00            | .00                 | .00           |
|                | AIRPORT-FAA GRANT AIP#19 TOTA  | .00             | 1,043.11       | 39,075.99      | .00                 | 39,075.99-    |
|                | CAP PROJECT-MISSOURI AVE TOTA  | .00             | .00            | .00            | .00                 | .00           |
|                | CAP PROJ-RAND PARK BLUFF TOTA  | .00             | .00            | .00            | .00                 | .00           |
|                | RIVER MUSEUM PROJECT TOTAL     | .00             | .00            | .00            | .00                 | .00           |
|                | CEMETERY STREE PROJECT TOTAL   | .00             | .00            | .00            | .00                 | .00           |
|                | AQUATIC CENTER TOTAL           | .00             | .00            | .00            | .00                 | .00           |
|                | YEAR END PROFIT HANDLER TOTAL  | .00             | .00            | .00            | .00                 | .00           |
|                | CAPITAL PROJECTS TOTAL         | 500,000.00      | 11,872.83      | 627,356.39     | 125.47              | 127,356.39-   |
|                | WPC MAINTENANCE & OPERATI TOTA | 2,415,378.00    | 176,051.43     | 1,280,771.42   | 53.03               | 1,134,606.58  |
|                | INDUSTRIAL PRETREATMENT TOTAL  | .00             | 459.50         | 459.50         | .00                 | 459.50-       |
|                | SANITARY SEWER MAINTENANC TOTA | 1,547,492.00    | 42,553.61      | 397,126.21     | 25.66               | 1,150,365.79  |
|                | CAP PROJ-LIFT STATIONS TOTAL   | 750,000.00      | .00            | 7,166.51       | .96                 | 742,833.49    |
|                | STORM SEWER SEPARATION TOTAL   | .00             | 4,247.60       | 290,195.07     | .00                 | 290,195.07-   |
|                | GRIT BASIN PROJECT TOTAL       | .00             | .00            | .00            | .00                 | .00           |
|                | REFUSE COLLECTION TOTAL        | 772,476.00      | 88,918.61      | 386,785.26     | 50.07               | 385,690.74    |
|                | LEACHATE CONTROL TOTAL         | 50,000.00       | 11,470.28      | 62,089.95      | 124.18              | 12,089.95-    |
|                | MUNICIPAL BRIDGE TOTAL         | 451,360.00      | 20,252.42      | 167,373.77     | 37.08               | 283,986.23    |
|                | CAP EQUIP/RESV-MUN BRIDGE TOTA | .00             | .00            | .00            | .00                 | .00           |
|                | REGIONAL TRANSIT TOTAL         | .00             | 2,125.00       | 6,375.00       | .00                 | 6,375.00-     |
|                | YEAR END PROFIT HANDLER TOTAL  | .00             | .00            | .00            | .00                 | .00           |
|                | ENTERPRISE FUNDS TOTAL         | 5,986,706.00    | 346,078.45     | 2,598,342.69   | 43.40               | 3,388,363.31  |
|                | TOTAL                          | .00             | .00            | .00            | .00                 | .00           |
|                | TRANSFERS TOTAL                | 5,820,444.00    | .00            | .00            | .00                 | 5,820,444.00  |
|                | TRANSFER TOTAL                 | .00             | .00            | 2,300,000.00   | .00                 | 2,300,000.00- |
|                | NON-PROGRAM GENERAL REV TOTAL  | .00             | 255.43         | 289,291.96     | .00                 | 289,291.96-   |
|                | YEAR END PROFIT HANDLER TOTAL  | .00             | .00            | .00            | .00                 | .00           |
|                | TRANSFER OUT TOTAL             | 5,820,444.00    | 255.43         | 2,589,291.96   | 44.49               | 3,231,152.04  |

**BUDGET REPORT**  
**CALENDAR 1/2018, FISCAL 7/2018**

**PCT OF FISCAL YTD 58.3%**

| <b>ACCOUNT NUMBER</b> | <b>ACCOUNT TITLE</b> | <b>TOTAL<br/>BUDGET</b> | <b>PTD<br/>BALANCE</b> | <b>YTD<br/>BALANCE</b> | <b>PERCENT<br/>EXPENDED</b> | <b>UNEXPENDED</b> |
|-----------------------|----------------------|-------------------------|------------------------|------------------------|-----------------------------|-------------------|
|                       | TOTAL ALL FUNCTIONS  | 24,587,510.00           | 1,463,899.75           | 12,810,522.87          | 52.10                       | 11,776,987.13     |
|                       |                      | =====                   | =====                  | =====                  | =====                       | =====             |

**BUDGET REPORT**  
**CALENDAR 1/2018, FISCAL 7/2018**

**PCT OF FISCAL YTD 58.3%**

| ACCOUNT NUMBER | ACCOUNT TITLE                  | TOTAL<br>BUDGET | PTD<br>BALANCE | YTD<br>BALANCE | PERCENT<br>EXPENDED | UNEXPENDED   |
|----------------|--------------------------------|-----------------|----------------|----------------|---------------------|--------------|
|                | GENERAL TOTAL                  | 9,339,558.00    | 946,971.93     | 5,807,868.68   | 62.19               | 3,531,689.32 |
|                | ROAD USE TAX TOTAL             | 1,037,206.00    | 62,300.08      | 509,658.35     | 49.14               | 527,547.65   |
|                | EMPLOYEE BENEFITS TOTAL        | 1,900,000.00    | .00            | 800,000.00     | 42.11               | 1,100,000.00 |
|                | EMERGENCY TAX LEVY FUND TOTAL  | 85,190.00       | .00            | .00            | .00                 | 85,190.00    |
|                | SALES TAX - HUMAN DEV TOTAL    | 140,000.00      | .00            | .00            | .00                 | 140,000.00   |
|                | SALES TAX - INFRASTRUCTUR TOTA | 1,000,000.00    | .00            | 500,000.00     | 50.00               | 500,000.00   |
|                | 50% SALES TAX-PROP TAX RE TOTA | 1,495,000.00    | .00            | 1,000,000.00   | 66.89               | 495,000.00   |
|                | TAX INCREMENT FINANCING TOTAL  | 1,200,254.00    | .00            | 16,741.00      | 1.39                | 1,183,513.00 |
|                | ECONOMIC DEVELOPMENT TOTAL     | .00             | 95,809.00      | 499,017.53     | .00                 | 499,017.53-  |
|                | SWIM POOL RESERVE TOTAL        | .00             | .00            | .00            | .00                 | .00          |
|                | GRAND THEATRE RESERVE TOTAL    | .00             | .00            | .00            | .00                 | .00          |
|                | MARY E TOLMIE FUND TOTAL       | .00             | .00            | .00            | .00                 | .00          |
|                | PARK MAINT & IMPROV RESER TOTA | .00             | .00            | .00            | .00                 | .00          |
|                | LIBRARY TRUST FUNDS TOTAL      | .00             | 612.03         | 4,948.77       | .00                 | 4,948.77-    |
|                | PUBLIC WORKS EQUIP RESERV TOTA | .00             | .00            | .00            | .00                 | .00          |
|                | DEBT SERVICE TOTAL             | 1,903,596.00    | .00            | 157,297.50     | 8.26                | 1,746,298.50 |
|                | CAPITAL PROJECTS TOTAL         | 500,000.00      | 4,568.22       | 620,051.78     | 124.01              | 120,051.78-  |

**BUDGET REPORT**  
**CALENDAR 1/2018, FISCAL 7/2018**

**PCT OF FISCAL YTD 58.3%**

| ACCOUNT NUMBER | ACCOUNT TITLE                  | TOTAL<br>BUDGET | PTD<br>BALANCE | YTD<br>BALANCE | PERCENT<br>EXPENDED | UNEXPENDED    |
|----------------|--------------------------------|-----------------|----------------|----------------|---------------------|---------------|
|                | RIVERFRONT BARGE PROJECT TOTA  | .00             | .00            | .00            | .00                 | .00           |
|                | ROQUETTE BUILDING TOTAL        | .00             | 7,304.61       | 7,304.61       | .00                 | 7,304.61-     |
|                | NON-EXPENDABLE TRUST FUND TOTA | .00             | .00            | .00            | .00                 | .00           |
|                | WPC MAINT & OPERATION TOTAL    | 3,223,370.00    | 170,610.79     | 1,349,216.50   | 41.86               | 1,874,153.50  |
|                | WATER POL CONTROL RESERVE TOTA | 237,000.00      | .00            | .00            | .00                 | 237,000.00    |
|                | SEWER MAINTENANCE RESERVE TOTA | 252,500.00      | .00            | 261,913.88     | 103.73              | 9,413.88-     |
|                | WATER POL CONTR CAP PROJ TOTA  | .00             | .00            | .00            | .00                 | .00           |
|                | SEWER IMPROVEMENT RESERVE TOTA | 1,000,000.00    | 52,701.35      | 364,588.33     | 36.46               | 635,411.67    |
|                | CDBG SWR POINT REPAIR PRJ TOTA | .00             | .00            | .00            | .00                 | .00           |
|                | SOLID WASTE FUND TOTAL         | 822,476.00      | 100,388.89     | 448,875.21     | 54.58               | 373,600.79    |
|                | SOL WAS EQUIP REPLACE RES TOTA | .00             | .00            | .00            | .00                 | .00           |
|                | CAP PROJ-REMEDIAL ACTION TOTA  | .00             | .00            | .00            | .00                 | .00           |
|                | MUNICIPAL BRIDGE TOTAL         | 451,360.00      | 22,377.42      | 173,748.77     | 38.49               | 277,611.23    |
|                | INTERNAL SERVICE FUND TOTAL    | .00             | 255.43         | 289,291.96     | .00                 | 289,291.96-   |
|                | TOTAL EXPENSES BY FUND         | =====           | =====          | =====          | =====               | =====         |
|                |                                | 24,587,510.00   | 1,463,899.75   | 12,810,522.87  | 52.10               | 11,776,987.13 |
|                |                                | =====           | =====          | =====          | =====               | =====         |

**REVENUE REPORT**  
**CALENDAR 1/2018, FISCAL 7/2018**

**PCT OF FISCAL YTD 58.3%**

| ACCOUNT NUMBER | ACCOUNT TITLE                  | FISCAL ESTIMATE | PTD BALANCE | YTD BALANCE  | PERCENT RECVD | UNCOLLECTED  |
|----------------|--------------------------------|-----------------|-------------|--------------|---------------|--------------|
|                | GENERAL TOTAL                  | 8,974,731.00    | 72,259.82   | 5,366,975.24 | 59.80         | 3,607,755.76 |
|                | ROAD USE TAX TOTAL             | 1,250,000.00    | 89,930.24   | 840,020.49   | 67.20         | 409,979.51   |
|                | EMPLOYEE BENEFITS TOTAL        | 1,966,905.00    | 27,243.36   | 1,094,949.99 | 55.67         | 871,955.01   |
|                | EMERGENCY TAX LEVY FUND TOTAL  | 85,190.00       | 1,029.32    | 51,885.69    | 60.91         | 33,304.31    |
|                | SALES TAX - HUMAN DEV TOTAL    | 140,000.00      | 11,761.63   | 83,269.94    | 59.48         | 56,730.06    |
|                | SALES TAX - INFRASTRUCTUR TOTA | 550,000.00      | 47,046.51   | 333,079.66   | 60.56         | 216,920.34   |
|                | 50% SALES TAX-PROP TAX RE TOTA | 770,000.00      | 58,808.14   | 416,349.58   | 54.07         | 353,650.42   |
|                | TAX INCREMENT FINANCING TOTAL  | 1,269,916.00    | 6,270.33    | 657,051.92   | 51.74         | 612,864.08   |
|                | ECONOMIC DEVELOPMENT TOTAL     | 27,000.00       | 100,572.73  | 307,921.44   | 1,140.45      | 280,921.44-  |
|                | SWIM POOL RESERVE TOTAL        | .00             | .00         | .00          | .00           | .00          |
|                | GRAND THEATRE RESERVE TOTAL    | .00             | .00         | .00          | .00           | .00          |
|                | MARY E TOLMIE FUND TOTAL       | .00             | .00         | .00          | .00           | .00          |
|                | PARK MAINT & IMPROV RESER TOTA | 5,000.00        | .00         | 82,968.34    | 1,659.37      | 77,968.34-   |
|                | LIBRARY TRUST FUNDS TOTAL      | .00             | 3,225.00    | 15,026.25    | .00           | 15,026.25-   |
|                | PUBLIC WORKS EQUIP RESERV TOTA | .00             | .00         | .00          | .00           | .00          |
|                | DEBT SERVICE TOTAL             | 1,931,004.00    | 8,027.69    | 418,426.97   | 21.67         | 1,512,577.03 |
|                | CAPITAL PROJECTS TOTAL         | .00             | 82,859.00   | 557,944.88   | .00           | 557,944.88-  |

**REVENUE REPORT**  
**CALENDAR 1/2018, FISCAL 7/2018**

**PCT OF FISCAL YTD 58.3%**

| ACCOUNT NUMBER | ACCOUNT TITLE                  | FISCAL ESTIMATE | PTD BALANCE | YTD BALANCE   | PERCENT RECVD | UNCOLLECTED  |
|----------------|--------------------------------|-----------------|-------------|---------------|---------------|--------------|
|                | RIVERFRONT BARGE PROJECT TOTA  | .00             | .00         | .00           | .00           | .00          |
|                | ROQUETTE BUILDING TOTAL        | .00             | .00         | .00           | .00           | .00          |
|                | NON-EXPENDABLE TRUST FUND TOTA | 3,000.00        | .00         | 22,282.54     | 742.75        | 19,282.54-   |
|                | WPC MAINT & OPERATION TOTAL    | 4,539,300.00    | 327,216.69  | 2,335,261.44  | 51.45         | 2,204,038.56 |
|                | WATER POL CONTROL RESERVE TOTA | 400.00          | .00         | 445.79        | 111.45        | 45.79-       |
|                | SEWER MAINTENANCE RESERVE TOTA | .00             | .00         | .00           | .00           | .00          |
|                | WATER POL CONTR CAP PROJ TOTA  | .00             | .00         | .00           | .00           | .00          |
|                | SEWER IMPROVEMENT RESERVE TOTA | .00             | .00         | 5,321.83      | .00           | 5,321.83-    |
|                | CDBG SWR POINT REPAIR PRJ TOTA | .00             | .00         | .00           | .00           | .00          |
|                | SOLID WASTE FUND TOTAL         | 761,000.00      | 55,411.83   | 368,796.19    | 48.46         | 392,203.81   |
|                | SOL WAS EQUIP REPLACE RES TOTA | .00             | .00         | .00           | .00           | .00          |
|                | CAP PROJ-REMEDIAL ACTION TOTA  | .00             | .00         | .00           | .00           | .00          |
|                | MUNICIPAL BRIDGE TOTAL         | 430,000.00      | 24,235.00   | 182,018.49    | 42.33         | 247,981.51   |
|                | INTERNAL SERVICE FUND TOTAL    | 485,000.00      | 46,389.51   | 336,121.17    | 69.30         | 148,878.83   |
|                | TOTAL REVENUES                 | =====           | =====       | =====         | =====         | =====        |
|                |                                | 23,188,446.00   | 962,286.80  | 13,476,117.84 | 58.12         | 9,712,328.16 |
|                |                                | =====           | =====       | =====         | =====         | =====        |

| HOL<br>FUND# | TITLE                   | LAST REPORT<br>ON HAND | EXPENSES     | REVENUE    | BALANCE       |
|--------------|-------------------------|------------------------|--------------|------------|---------------|
| 001          | GENERAL                 | 1,084,061.93           | 946,971.93   | 72,259.82  | 297,375.36    |
| 110          | ROAD USE TAX            | 1,530,592.39           | 62,300.08    | 89,930.24  | 1,568,817.35  |
| 112          | EMPLOYEE BENEFITS       | 1,051,797.88           | .00          | 27,243.36  | 1,079,041.24  |
| 119          | EMERGENCY TAX LEVY FUND | 54,643.11              | .00          | 1,029.32   | 55,672.43     |
| 121          | SALES TAX - HUMAN DEV   | 138,354.17             | .00          | 11,761.63  | 150,115.80    |
| 122          | SALES TAX - INFRASTRUCT | 326,435.38             | .00          | 47,046.51  | 373,481.89    |
| 123          | 50% SALES TAX-PROP TAX  | 363,857.62             | .00          | 58,808.14  | 422,665.76    |
| 125          | TAX INCREMENT FINANCING | 646,664.20             | .00          | 6,270.33   | 652,934.53    |
| 160          | ECONOMIC DEVELOPMENT    | 99,827.90-             | 95,809.00    | 100,572.73 | 95,064.17-    |
| 182          | SWIM POOL RESERVE       | 1,070.00               | .00          | .00        | 1,070.00      |
| 183          | GRAND THEATRE RESERVE   | 1,051.17               | .00          | .00        | 1,051.17      |
| 184          | MARY E TOLMIE FUND      | 81,873.04              | .00          | .00        | 81,873.04     |
| 185          | PARK MAINT & IMPROV RES | 216,300.88             | .00          | .00        | 216,300.88    |
| 186          | LIBRARY TRUST FUNDS     | 54,863.70              | 612.03       | 3,225.00   | 57,476.67     |
| 187          | PUBLIC WORKS EQUIP RESE | 12,800.78              | .00          | .00        | 12,800.78     |
| 200          | DEBT SERVICE            | 365,364.14             | .00          | 8,027.69   | 373,391.83    |
| 301          | CAPITAL PROJECTS        | 810,229.13             | 4,568.22     | 82,859.00  | 888,519.91    |
| 302          | RIVERFRONT BARGE PROJEC | .00                    | .00          | .00        | .00           |
| 303          | ROQUETTE BUILDING       | .00                    | 7,304.61     | .00        | 7,304.61-     |
| 500          | NON-EXPENDABLE TRUST FU | 466,432.03             | .00          | .00        | 466,432.03    |
| 610          | WPC MAINT & OPERATION   | 4,518,149.31           | 170,610.79   | 327,216.69 | 4,693,514.67  |
| 611          | WATER POL CONTROL RESER | 95,348.84-             | .00          | .00        | 95,348.84-    |
| 612          | SEWER MAINTENANCE RESER | 882,971.98-            | .00          | .00        | 882,971.98-   |
| 613          | WATER POL CONTR CAP PRO | .00                    | .00          | .00        | .00           |
| 614          | SEWER IMPROVEMENT RESER | 650,418.27             | 52,701.35    | .00        | 597,716.92    |
| 617          | CDBG SWR POINT REPAIR P | .00                    | .00          | .00        | .00           |
| 670          | SOLID WASTE FUND        | 98,995.03              | 100,388.89   | 55,411.83  | 61,405.77     |
| 671          | SOL WAS EQUIP REPLACE R | .00                    | .00          | .00        | .00           |
| 672          | CAP PROJ-REMEDIAL ACTIO | .00                    | .00          | .00        | .00           |
| 690          | MUNICIPAL BRIDGE        | 3,023,457.59           | 22,377.42    | 24,235.00  | 3,027,555.75  |
| 810          | INTERNAL SERVICE FUND   | 1,410.95               | 255.43       | 46,389.51  | 47,545.03     |
|              | Report Total            | 14,420,673.98          | 1,463,899.75 | 962,286.80 | 14,046,069.21 |

**RESOLUTION NO.**

**WHEREAS**, The City Council of the City of Keokuk has adopted provisions for Urban Revitalization Tax Exemption and;

**WHEREAS**, Applications have been submitted;

**BE IT RESOLVED BY THE CITY COUNCIL OF THE CITY OF KEOKUK, IOWA, THAT:**

An Urban Revitalization Tax Exemption for the following home owners be approved:

- Aaron & Tammy Smith, 524 Hawthorne St., Addition & detached garage
- Steve & Orma Andrews, 1710 Park St., partial basement, kitchen and breezeway addition and interior remodel
- Nancy Meinhardt, 2945 Middle Road, single family dwelling

Passed this 1<sup>st</sup> day of February, 2018.

CITY OF KEOKUK, LEE COUNTY, IOWA

By: \_\_\_\_\_  
THOMAS L. RICHARDSON, MAYOR

ATTEST: \_\_\_\_\_  
JEAN LUDWIG, CITY CLERK

January 23, 2018

Honorable Mayor, City of Keokuk  
P. O. Box 400  
Keokuk, IA 52632

Honorable Mayor:

Please accept this application for urban revitalization tax exemption (as adopted by City Ordinance No. 1716) for my improvement project located at 1710 Park Street.

As per the guidelines set forth in Section 404, of the Iowa Code, which deals with applying for an exemption, please find in the succeeding paragraphs the following information:

- Nature of the improvement
- Cost of the improvement
- Estimated date of completion
- Tenants that occupied the owner's building on the April 1, 2001
- Elected exemption as prescribed by ordinance

My project is (describe in detail): **partial basement, kitchen/breezeway addition and interior remodel**

The estimated cost of the completed project is \$55,000.00 and it will be completed on, February 1, 2018 .

The tenants that now occupy the property are the same tenants that occupied the property on April 1, 2001, or I am the owner-occupant, or:

Because my building is a new building, there were no tenants occupying my building on April 1, 2001.

Upon approval of my application for tax exempt status, the exemption schedule as specified in Section 404.3, subsection 3: ".....qualified real estate is eligible to receive a one-hundred percent exemption from taxation on the actual value added by the improvements. The exemption is for a period of three years."

I hope you find this application acceptable. Please let me know if you need additional information.

Sincerely,

  
\_\_\_\_\_  
Property Owner(s) Signature

**APPLICATION FOR URBAN REVITALIZATION EXEMPTION**

Pursuant to the provisions of Iowa Code Chapter 404 and Ordinance 1716 of the City of Keokuk, application is made for an Urban Revitalization Tax Exemption. This application to be filed with the City of Keokuk by February 1, of the assessment year for which the exemption is first claimed, but not later than the year in which all improvements included in the project are first assessed for taxation.

Property Owner Name: **Steve & Orma Andrews**

Property Owner Address: **1710 Park Street**

Address of Residential Property Claimed for Exemption: **1710 Park Street**

All qualified real estate is eligible to receive a one-hundred percent exemption from taxation on the actual value added by improvements. The exemption is for three years.

1. If applicable, describe in detail the new construction for which an exemption is claimed:  
**Partial basement, kitchen and breezeway addition**
2. If applicable, describe in detail the reconstruction of existing buildings or structures:  
**Interior remodel**
3. Was prior approval given by the City Council for this exemption?  
Yes:  (by Res. No. \_\_\_\_\_) No:
4. Estimated costs of the improvements? **\$55,000.00**
5. Estimated or actual date of completion? **February 1, 2018**
6. Please provide the names of tenants that occupied the building on April 1, 2001. See Iowa Code Section 404.6 with regard to relocation expenses of tenants.

I hereby swear that the information presented on this application and all attached supporting documents are true, correct and complete.

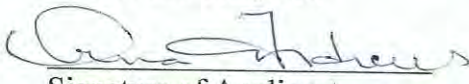
  
Signature of Applicant

Property Owner  
Title

1-23-18  
Date

***FOR ASSESSOR USE ONLY***

I have examined this application for urban revitalization tax exemption and hereby certify \$ \_\_\_\_\_ of the 20\_\_ final taxable value qualifies for urban revitalization tax exemption.

\_\_\_\_\_  
Assessor Signature

\_\_\_\_\_  
Date

October 5, 2017

Honorable Mayor, City of Keokuk  
P. O. Box 400  
Keokuk, IA 52632

Honorable Mayor:

Please accept this application for urban revitalization tax exemption (as adopted by City Ordinance No. 1716) for my improvement project located at 528 Hawthorne.

As per the guidelines set forth in Section 404, of the Iowa Code, which deals with applying for an exemption, please find in the succeeding paragraphs the following information:

- Nature of the improvement
- Cost of the improvement
- Estimated date of completion
- Tenants that occupied the owner's building on the April 1, 2001
- Elected exemption as prescribed by ordinance

My project is (describe in detail): **Home addition and new garage**

The estimated cost of the completed project is \$50,090.00 and it will be completed on, 1/30/2018.

The tenants that now occupy the property are the same tenants that occupied the property on April 1, 2001, or I am the owner-occupant, or:

Because my building is a new building, there were no tenants occupying my building on April 1, 2001.

Upon approval of my application for tax exempt status, the exemption schedule as specified in Section 404.3, subsection 3: ".....qualified real estate is eligible to receive a one-hundred percent exemption from taxation on the actual value added by the improvements. The exemption is for a period of three years."

I hope you find this application acceptable. Please let me know if you need additional information.

Sincerely,



Property Owner(s) Signature

**APPLICATION FOR URBAN REVITALIZATION EXEMPTION**

Pursuant to the provisions of Iowa Code Chapter 404 and Ordinance 1716 of the City of Keokuk, application is made for an Urban Revitalization Tax Exemption. This application to be filed with the City of Keokuk by February 1, of the assessment year for which the exemption is first claimed, but not later than the year in which all improvements included in the project are first assessed for taxation.

Property Owner Name: **Aaron & Tammy Smith**

Property Owner Address: **528 Hawthorne**

Address of Residential Property Claimed for Exemption: **528 Hawthorne**

All qualified real estate is eligible to receive a one-hundred percent exemption from taxation on the actual value added by improvements. The exemption is for three years.

1. If applicable, describe in detail the new construction for which an exemption is claimed:  
**Garage**
2. If applicable, describe in detail the reconstruction of existing buildings or structures:  
**Home addition**
3. Was prior approval given by the City Council for this exemption?  
Yes:  (by Res. No. \_\_\_\_\_) No:
4. Estimated costs of the improvements? **\$50,090.00**
5. Estimated or actual date of completion?
6. Please provide the names of tenants that occupied the building on April 1, 2001. See Iowa Code Section 404.6 with regard to relocation expenses of tenants.

I hereby swear that the information presented on this application and all attached supporting documents are true, correct and complete.

Aaron Smith  
Signature of Applicant

Property Owner  
Title

11/6/17  
Date

***FOR ASSESSOR USE ONLY***

I have examined this application for urban revitalization tax exemption and hereby certify \$\_\_\_\_\_ of the 20\_\_ final taxable value qualifies for urban revitalization tax exemption.

\_\_\_\_\_  
Assessor Signature

\_\_\_\_\_  
Date



January 30, 2018

Honorable Mayor, City of Keokuk  
P. O. Box 400  
Keokuk, IA 52632

Honorable Mayor:

Please accept this application for urban revitalization tax exemption (as adopted by City Ordinance No. 1716) for my improvement project located at **2945 Middle Road.**

As per the guidelines set forth in Section 404, of the Iowa Code, which deals with applying for an exemption, please find in the succeeding paragraphs the following information:

- Nature of the improvement
- Cost of the improvement
- Estimated date of completion
- Tenants that occupied the owner's building on the April 1, 2001
- Elected exemption as prescribed by ordinance

My project is (describe in detail): **Single family dwelling**

The estimated cost of the completed project is **\$350,000.00** and it will be completed on, **January 2018.**

The tenants that now occupy the property are the same tenants that occupied the property on April 1, 2001, or I am the owner-occupant, or:

Because my building is a new building, there were no tenants occupying my building on April 1, 2001.

Upon approval of my application for tax exempt status, the exemption schedule as specified in Section 404.3, subsection 3: ".....qualified real estate is eligible to receive a one-hundred percent exemption from taxation on the actual value added by the improvements. The exemption is for a period of three years."

I hope you find this application acceptable. Please let me know if you need additional information.

Sincerely,

  
\_\_\_\_\_  
Property Owner(s) Signature

**PAYMENT OF THE FOLLOWING CLAIMS FOR THE CITY ARE APPROVED AND CLAIMS FOR THE LIBRARY AND AIRPORT ARE ACKNOWLEDGED FOR THE PURPOSE OF PAYING THE SEMI-MONTHLY BILLS FOR THE COUNCIL MEETING OF FEBRUARY 1, 2018.**

**REGISTER NO. 4977**

|                                |                                |    |            |
|--------------------------------|--------------------------------|----|------------|
| AMI PIPE & SUPPLY              | SUPPLIES                       | \$ | 53.05      |
| BEARING HEADQUARTERS CO.       | PARTS                          | \$ | 5,380.85   |
| KEOKUK MUNICIPAL WATER WORKS   | FROZEN METER/REPAIRS           | \$ | 392.51     |
| GATE CITY PUBLISHING           | PUBLICATIONS                   | \$ | 267.79     |
| KEOKUK TERMITE & PEST CONTROL  | PEST CONTROL                   | \$ | 182.50     |
| JIM BAIER, INC                 | PARTS                          | \$ | 125.78     |
| ERIC E. SUTER                  | SERVICE CALL                   | \$ | 65.00      |
| RIVER CITY PARTS, INC.         | PARTS                          | \$ | 192.09     |
| LAWSON PRODUCTS, INC.          | SUPPLIES                       | \$ | 12.31      |
| KERR FABRICATORS, INC.         | PARTS/SUPPLIES                 | \$ | 167.50     |
| J & S ELECTRONICS BUSINESS,INC | MAINTENANCE AGREEMENT          | \$ | 177.67     |
| S. J. SMITH WELDING SUPPLY     | TANK RENTAL                    | \$ | 49.50      |
| IDEAL READY MIX COMPANY, INC   | CONCRETE                       | \$ | 167.50     |
| JERRY'S WELDING                | LABOR/PARTS                    | \$ | 1,038.00   |
| KEYSTONE LABORATORIES, INC.    | TEST SAMPLES                   | \$ | 200.00     |
| MEYERS DRIVEWAY & SEPTIC TANK  | RENTAL/PORTABLE TOILETS        | \$ | 675.00     |
| BAKER & TAYLOR BOOKS           | BOOKS KEOKUK PUBLIC LIBRARY    | \$ | 430.19     |
| ALLIANT                        | ELECTRIC BILL                  | \$ | 21,186.21  |
| THE CARDBOARD BOX              | UPS CHARGES                    | \$ | 42.53      |
| VISION SERVICE PLAN            | VISION COVERAGE                | \$ | 3,148.56   |
| CENTURY LINK                   | SERVICE                        | \$ | 832.41     |
| GREAT RIVER REGIONAL WASTE     | INTEGRATED WASTE SERVICES      | \$ | 7,124.82   |
| AIRGAS USA, LLC                | SAFETY/WORK GLOVES             | \$ | 48.72      |
| LINDNER AVIATION, INC.         | AIRPORT MANAGER/MAINT          | \$ | 5,220.21   |
| FAIRCHILD COMMUNICATIONS       | AIRNDB MAINTENANCE             | \$ | 135.00     |
| KEOKUK AREA HOSPITAL           | MEDICAL SERVICES               | \$ | 109.33     |
| DEMCO, INC                     | SUPPLIES KEOKUK PUBLIC LIBRARY | \$ | 379.26     |
| IOWA DEPT. OF PUBLIC SAFETY    | TERMINAL BILLING               | \$ | 300.00     |
| MEYERS PLUMBING                | MATERIALS/LABOR TUMELTY PARK   | \$ | 852.29     |
| MODJESKI & MASTERS, INC.       | BRIDGE INSPECTION              | \$ | 725.00     |
| KEOKUK CONTRACTORS, INC        | CRANE RENTAL/REPAIRS           | \$ | 1,068.50   |
| GOODYEAR AUTO SERVICE CENTER   | TIRES                          | \$ | 546.40     |
| HUFFMAN MACHINE & WELDING, INC | SUPPLIES/PARTS                 | \$ | 330.38     |
| ENDERLE HEATING & A/C COMPANY  | PARTS/LABOR                    | \$ | 214.70     |
| RATHBUN REGIONAL WATER ASSOC.  | AIRPORT WATER BILL             | \$ | 16.47      |
| W. L. MILLER COMPANY           | AIRPORT OBSTRUCTION PAY #1     | \$ | 117,610.00 |
| DOWNEY'S FIRE EQUIPMENT        | RECHARGE EXTINGUISHER          | \$ | 20.00      |
| HILL PRINTING                  | RED TOW STICKERS POLICE DEPT   | \$ | 310.90     |
| HY-VEE, INC.                   | SUPPLIES                       | \$ | 154.45     |
| PER MAR SECURITY SERVICES      | SERVICE CALL/SECURITY MONITOR  | \$ | 540.41     |
| NBS CALIBRATIONS               | LAB SUPPLIES @ WPC             | \$ | 164.00     |

**REGISTER NO. 4978**

|                                |                                |    |            |
|--------------------------------|--------------------------------|----|------------|
| OVERHEAD DOOR COMPANY OF       | SERVICE/LABOR RAND PARK        | \$ | 294.42     |
| NORTH CENTRAL LABORATORIES     | LAB SUPPLIES                   | \$ | 134.22     |
| YOUNGGREN SHOES                | WORK BOOTS                     | \$ | 120.00     |
| NIEMANN FOODS, INC./ACE        | SUPPLIES                       | \$ | 49.27      |
| RANDY WINN                     | REIMB.HEALTH INSURANCE PREMIUM | \$ | 335.00     |
| IOWA PRISON INDUSTRIES         | SIGN POST                      | \$ | 112.80     |
| CHEMSEARCH                     | SUPPLIES                       | \$ | 696.50     |
| FULL COMPASS SYSTEMS, LTD      | SCENIC ROLLER GRAND THEATER    | \$ | 1,805.88   |
| TERMINAL SUPPLY CO.            | LED LIGHTS/FREIGHT             | \$ | 130.81     |
| FASTENAL COMPANY               | PARTS/SUPPLIES                 | \$ | 243.20     |
| ECKLAND MOTORS                 | POLICE VEHICLE                 | \$ | 12,850.00  |
| SEARS COMMERCIAL ONE           | PARTS/TOOLS/SUPPLIES           | \$ | 699.97     |
| KEOKUK FARM & HOME SUPPLY      | SUPPLIES                       | \$ | 2,258.56   |
| XEROX CORPORATION              | LEASE                          | \$ | 311.01     |
| WAL-MART COMMUNITY/GECRB       | SUPPLIES                       | \$ | 419.88     |
| KEVIN CHURCH                   | REIMBURSE TAX ERROR            | \$ | 13.65      |
| DES MOINES STAMP MANUFACTURING | DEPOSIT STAMP/SHIPPING         | \$ | 33.40      |
| POLYDYNE, INC.                 | POLYMER - WPC                  | \$ | 22,448.00  |
| PETERS HEATING & AIR           | PARTS/LABOR @ WPC              | \$ | 112.50     |
| HNTB CORPORATION               | ENGINEERING FEES               | \$ | 7,429.52   |
| EMC NATIONAL LIFE COMPANY      | INSURANCE PREMIUM              | \$ | 1,238.83   |
| IOWA PARKS & RECREATION ASSOC. | AQUATIC CEU WORKSHOP           | \$ | 145.00     |
| MEDIACOM                       | SERVICES @ LIBRARY             | \$ | 143.40     |
| LCL FARMS INC.                 | BIO SOLID TRUCKING/SPREADING   | \$ | 16,022.39  |
| DELUXE CLEANERS                | DRY CLEAN PD UNIFORM           | \$ | 9.40       |
| HILL'S PET NUTRITION SALES,INC | SUPPLIES                       | \$ | 88.61      |
| CANTON MARINE TOWING CO.INC.   | SECURE BARGE                   | \$ | 4,381.25   |
| WEF                            | MEMBERSHIP FEES                | \$ | 160.00     |
| EMPLOYEE BENEFIT SYSTEMS       | HEALTH INSURANCE               | \$ | 173,516.78 |
| SCHUMACHER ELEVATOR COMPANY    | LIBRAR ELEVATOR MAINT COVERAGE | \$ | 525.26     |
| ARNOLD REFRIGERATION, INC.     | PARTS/LABOR @ WPC              | \$ | 253.00     |
| RELIABLE PEST SOLUTIONS        | SERVICE KEOKUK PUBLIC LIBRARY  | \$ | 14.90      |
| MIDWEST JANITORIAL SERVICE,INC | JANITORIAL SERVICE @ LIBRARY   | \$ | 1,061.94   |
| NSI LAB SOLUTIONS              | LAB SUPPLIES                   | \$ | 380.00     |
| DRAKE-SCRUGGS EQUIPMENT, INC.  | AERIAL INSPECTION/DIELECTRIC   | \$ | 207.00     |
| WEST CENTRAL FS INC.           | BULK FUEL-DIESEL/BULK OIL      | \$ | 36,414.80  |
| INTERSTATE BATTERIES OF        | BATTERIES                      | \$ | 121.34     |
| TOM MARION                     | HOTEL/MILEAGE LEAGUE OF CITIES | \$ | 496.03     |
| WINDSTREAM                     | SERVICES                       | \$ | 1,585.07   |
| KOHLMORGAN HAULING             | WASTE MANAGEMENT               | \$ | 48.90      |
| LIBERTY UTILITIES MIDSTATES    | SERVICES                       | \$ | 4,782.68   |
| JAMES WALLACE                  | JANITORIAL SERVICE @ GRAND     | \$ | 305.00     |
| DIANNE STANLEY                 | MONTHLY MANAGER FEE @ GRAND    | \$ | 425.00     |
| INTERSTATE BILLING SERVICE,INC | PARTS                          | \$ | 169.27     |
| 3E ELECTRICAL ENGINEERING &    | LABOR/MILEAGE                  | \$ | 490.00     |

**REGISTER NO. 4979**

|                               |                               |    |            |
|-------------------------------|-------------------------------|----|------------|
| FULLSPEED LLC DBA EAGLE TECH  | DOMAIN RENEWAL/SERVICE CALL   | \$ | 129.18     |
| RICOH USA, INC.               | KEOKUK PUBLIC LIBRARY         | \$ | 35.33      |
| VISA                          | CARD SERVICES                 | \$ | 6,376.80   |
| KEOKUK MILLS, LLC             | TARGETED JOBS TAX CREDIT      | \$ | 5,631.63   |
| MT. PLEASANT CORRECTIONAL FAC | INMATE SERVICES               | \$ | 120.00     |
| AXON ENTERPRISE, INC          | TASER CARTRIDGES/BATTERIES    | \$ | 3,132.88   |
| STERICYCLE COMSOL             | ANSWERING SERVICE             | \$ | 473.93     |
| NATHAN DESPAIN                | REIMBURSE FUEL                | \$ | 15.00      |
| POWER PROCESS EQUIPMENT INC   | LABOR/REPAIRS WPC             | \$ | 3,960.02   |
| RIVER CITY AUDIO              | PARTS/INSTALLATION CITY TRUCK | \$ | 240.00     |
| UNITY POINT HEALTH            | MEDICAL SERVICES              | \$ | 15.00      |
|                               |                               |    |            |
|                               |                               | \$ | 484,272.00 |



ITEM NO. 7

**CITY OF KEOKUK**  
CITY COUNCIL AGENDA COMMUNICATION

Today's Date: January 30, 2018 Meeting Date: February 1, 2018

|   |   |
|---|---|
| <p>SUBJECT: Vacation and disposal of the 20' x 300' alley, Block 41, Reid's addition.</p> | <p>ACTION REQUIRED:</p> <p><input type="checkbox"/> Ordinance</p> <p><input checked="" type="checkbox"/> Resolution</p> <p><input type="checkbox"/> Approval</p> <p><input type="checkbox"/> Receive/File</p> |
|---|---|

|                       |  |
|-----------------------|--|
| <p>SYNOPSIS</p>       | <p>Roquette America, Inc. has proposed to construct buildings to house administrative office The City Planning Commission reviewed the request and recommended approval of the request. The City Council will hold a public hearing on February 1, 2018.</p> |
| <p>FISCAL IMPACT</p>  | <p>Recording fees</p>  |
| <p>RECOMMENDATION</p> | <p>Recommend approval</p>  |

Mandatory Attorney Review Completed: \_\_\_\_\_

Responsible City Staff Member(s): Pam Broomhall

**RESOLUTION NO.**

**A RESOLUTION TO VACATE AND TO DISPOSE OF THE ALLEY IN BLOCK 41, REIDS ADDITION, CITY OF KEOKUK, LEE COUNTY, IOWA.**

**WHEREAS**, a public hearing was held on February 1, 2018 by the Keokuk City Council on a request to vacate and dispose of city-owned right-of-way described as follows: 20' x 300' improved alley in Block 41, Reid's Addition to the City of Keokuk, Lee County, Iowa, and found to be of no benefit to the public and should be vacated; and

**WHEREAS**, pursuant to Iowa Code Section 354.23, the City Council declares its intent to dispose of this City right-of-way by conveying through this vacating instrument all its right, title, and interest in it to the abutting property owner(s); and

**WHEREAS**, this conveyance is subject to the reservation of a permanent and perpetual utilities easement of way in favor of the City of Keokuk, for the maintenance of any and all utilities equipment presently in place, and for such reconstruction, re-emplacment and repair thereof which said City and its licensees and/or franchise grantees may in the future deem necessary and proper, and for the removal of any improvements emplaced thereon by the grantees, or their successors or assigns, necessitated by the reconstruction, re-emplacment, or repair of such utilities, such removal to be at the sole expense of grantees or their successors or assigns and without cost to the City, its licensees and/or franchise grantees, and without obligation to repair or replace such improvements, and subject to any and all other easements and right-of way of record and those not of record.

**NOW, THEREFORE, BE IT RESOLVED BY THE CITY COUNCIL OF THE CITY OF KEOKUK, IOWA:** that the following described city right-of-way is hereby vacated and conveyed to Roquette America, Inc. and all successors in interest as follows: Beginning at the southeasterly corner of Lot 1, Block 41, Reid's Addition, thence south twenty (20') feet to the northeasterly corner of Lot 12, thence west three hundred (300') feet to the northwesterly corner of Lot 7, thence north twenty (20') feet to the southwesterly corner of Lot 6, thence east three hundred (300') feet to the southeasterly corner of Lot 1 and point of beginning.

**BE IT FURTHER RESOLVED**, that the Mayor and the City Clerk be and are hereby authorized, empowered and directed to take all necessary measures to convey the City's interest in the above-described alley right-of-way in consideration of sum certain to Roquette America, Inc. and

**BE IT FURTHER RESOLVED**, that the aforementioned vacation shall be reflected in Appendix A, Section 8 of the Keokuk Municipal Code, and a copy recorded with the Lee County Recorder of Deeds.

Passed this 1<sup>st</sup> day of February, 2018.

CITY OF KEOKUK, LEE COUNTY, IOWA

By: \_\_\_\_\_  
THOMAS L. RICHARDSON, MAYOR

ATTEST: \_\_\_\_\_  
JEAN LUDWIG, CITY CLERK



**RESOLUTION NO.**

A RESOLUTION APPROVING THE THIRD READING OF ORDINANCE 1979.

**BE IT HEREBY RESOLVED BY THE CITY COUNCIL OF THE CITY OF KEOKUK, IOWA:**

**THAT**, the Keokuk City Council approves the third and final reading of Ordinance No. 1979 Rezoning Lots 1 through 6, Block 41, Reid's Addition; Lots 1 & 2 from R-2, single family dwelling district to M-2, Heavy Industrial District and Lots 3, 4, 5 & 6 from R-3 two family dwelling to M-2, Heavy Industrial District.

MOVED BY:

SECONDED BY:

Passed this 1<sup>st</sup> day of February, 2018.

ROLL CALL:

AYES –

NAYS –

ABSENT –

\_\_\_\_\_  
THOMAS L. RICHARDSON, MAYOR

ATTEST:

\_\_\_\_\_  
JEAN LUDWIG, CITY CLERK



ITEM NO. 8

**CITY OF KEOKUK**  
CITY COUNCIL AGENDA COMMUNICATION

Today's Date: January 2, 2018 Meeting Date: February 1, 2018

|                                 |  |
|---------------------------------|--|
| <b><u>SUBJECT:</u></b> Rezoning | ACTION REQUIRED:<br><input checked="" type="checkbox"/> Ordinance<br><input type="checkbox"/> Resolution<br><input type="checkbox"/> Approval<br><input type="checkbox"/> Receive/File |
|---------------------------------|--|

|                |   |
|----------------|---|
| SYNOPSIS       | Roquette America, Inc has requested rezoning of the half block between B and C Streets and between the alley and South 7 <sup>th</sup> Street. Two of the lots are currently zoned R-2, single family, the other four lots are zoned R-3, two family, the request is to rezone to M-2 Heavy Industrial. Roquette has proposed to construct an office building at this location. |
| FISCAL IMPACT  | Recording and publishing fees   |
| RECOMMENDATION | City Planning Commission met on December 18, 2017, recommending approval of the rezoning request.   |

Mandatory Attorney Review Completed: \_\_\_\_\_

Responsible City Staff Member(s): Pam Broomhall, Community Development Director

**ORDINANCE NO. 1979**

**AN ORDINANCE AMENDING THE ZONING ORDINANCES OF THE CITY OF KEOKUK, LEE COUNTY, IOWA BY REZONING LOTS 1 & 2, BLOCK 41, REID'S ADDITION TO THE CITY OF KEOKUK, FROM AN R-2, SINGLE FAMILY DWELLING DISTRICT TO AN M-2, HEAVY INDUSTRIAL DISTRICT AND LOTS 3 THROUGH 6, BLOCK 41, REID'S ADDITION TO THE CITY OF KEOKUK, FROM R-3, TWO FAMILY DWELLING DISTRICT TO M-2, HEAVY INDUSTRIAL DISTRICT.**

**BE IT ORDAINED BY THE CITY COUNCIL OF THE CITY OF KEOKUK, LEE COUNTY IOWA;**

**SECTION 1.** The zoning ordinances of the City of Keokuk, Lee County, Iowa are hereby amended by rezoning the following described real estate from R-2, single-family dwelling, and R-3, two-family dwelling, to M-2, Heavy Industrial District, to wit:

Lots 1 & 2, Block 41, Reid's Addition to the City of Keokuk, from an R-2, single family dwelling district to an M-2, heavy industrial district and Lots 3 through 6, Block 41, Reid's Addition to the City of Keokuk, from R-3, two family dwelling district to M-2, heavy industrial district. The district boundaries shall extend to the centerline of abutting streets.

**SECTION 2. EFFECTIVE DATE**

This ordinance shall be in full force and effect from and after its final passage and publication, once in the Daily Gate City, a newspaper of general circulation, as required by law.

**SECTION 3. REPEALER CLAUSE**

All other ordinances or parts of ordinances in conflict with the provisions of this ordinance are hereby repealed.

**SECTION 4. SEVERABILITY.**

The provisions of this ordinance are severable, and if any section, clause, part or provision hereof shall be held to be illegal, invalid or unconstitutional by any court of competent jurisdiction, such decision of the court shall not affect or impair the remaining sections, sentences, clauses, parts or provisions of this ordinance. It is hereby declared to be the intent of the City Council that this ordinance would have been enacted as if such illegal, invalid, or unconstitutional section, sentence, clause, part, provision, or other subdivision had not been included herein.

**RESOLUTION NO. 1-18**

**INITIAL PASSAGE** this 4<sup>th</sup> day of January, 2018.

CITY OF KEOKUK, LEE COUNTY, IOWA

BY: \_\_\_\_\_  
THOMAS L. RICHARDSON, MAYOR

ATTEST: \_\_\_\_\_  
JEAN LUDWIG, CITY CLERK

ROLL CALL: O’CONNOR – AYE MOORE – ABSENT PAYNE – AYE DADE –  
AYE HELENTAL - ABSENT MORTIMER – AYE GREENWALD – AYE  
BRYANT – AYE DUNEK – AYE

AYES – 7

NAYS – 0

ABSENT – 2

**RESOLUTION NO. 6-18**

**SECOND PASSAGE** this 18<sup>th</sup> day of January, 2018.

CITY OF KEOKUK, LEE COUNTY, IOWA

BY: \_\_\_\_\_  
THOMAS L. RICHARDSON, MAYOR

ATTEST: \_\_\_\_\_  
JEAN LUDWIG, CITY CLERK

ROLL CALL: O’CONNOR – ABSENT MOORE – ABSENT PAYNE – AYE  
DADE – AYE HELENTAL – AYE MORTIMER – AYE GREENWALD – AYE  
BRYANT – AYE DUNEK – ABSENT

AYES – 6

NAYS – 0

ABSENT – 3



**RESOLUTION NO.**

A RESOLUTION APPROVING THE THIRD READING OF ORDINANCE 1980.

**BE IT HEREBY RESOLVED BY THE CITY COUNCIL OF THE CITY OF KEOKUK, IOWA:**

**THAT**, the Keokuk City Council approves the third and final reading of Ordinance No. 1980 Amending the code of ordinances of the City of Keokuk to repeal Chapter 2.50 and 2.16, and to adopt Chapter 1.15 regarding the method of City Elections.

MOVED BY:

SECONDED BY:

Passed this 1<sup>st</sup> day of February, 2018.

ROLL CALL:

AYES –

NAYS –

ABSENT –

\_\_\_\_\_  
THOMAS L. RICHARDSON, MAYOR

ATTEST:

\_\_\_\_\_  
JEAN LUDWIG, CITY CLERK

**ORDINANCE NO. 1980**

**AN ORDINANCE AMENDING THE CODE OF ORDINANCES OF THE CITY OF KEOKUK TO REPEAL CHAPTER 2.50 and 2.16, AND TO ADOPT CHAPTER 1.15 REGARDING THE METHOD OF CITY ELECTIONS**

**WHEREAS**, The City Council of the City of Keokuk finds that the Runoff election process is too cumbersome and needlessly expensive in elections for elected city officials; and

**WHEREAS**, State Law provides for multiple methods for election its officers; and

**WHEREAS**, the process in Chapter 45, nomination by petition, would lead to less expensive municipal elections and provide for more input from the community in the election of its officers; and

**WHEREAS**, the City Treasurer requirement has been eliminated from State Code for Mayor-Council forms of government; and

**WHEREAS**, the duties of the City Treasurer have already been vested in the Finance Director and City Administrator of the City of Keokuk, thus resulting in an additional and redundant step providing no meaningful input into the finances of the City, wherein mandated independent audits already provide necessary protections; now, therefore,

**BE IT ORDAINED**, by the City Council of the City of Keokuk, Lee County, Iowa, as follows:

SECTION ONE. Chapter 2.50 of the Keokuk Municipal Code, entitled “RUNOFF ELECTIONS” is hereby repealed in its entirety.

SECTION TWO. Chapter 2.16 of the Keokuk Municipal Code, entitled “CITY TREASURER” is hereby repealed in its entirety.

SECTION THREE. Chapter 1.15, entitled “City Elections”, is hereby adopted, reading as follows:

**CITY ELECTIONS**

**1.15.01 NOMINATING METHOD TO BE USED.**

All candidates for elective municipal offices shall be nominated under the provisions of Chapter 45 of the Code of Iowa. (Code of Iowa, Sec. 376.3)

**1.15.02 NOMINATIONS BY PETITION.**

Nominations for elective municipal offices of the City may be made by nomination paper or papers signed by not less than twenty-five (25) eligible electors, who shall be residents of the City. (Code of Iowa, Sec. 45.1)

#### 1.15.03 ADDING NAME BY PETITION.

The name of a candidate placed upon the ballot by any other method than by petition shall not be added by petition for the same office. (Code of Iowa, Sec. 45.2)

#### 1.15.04 PREPARATION OF PETITION AND AFFIDAVIT.

Nomination papers shall include a petition and an affidavit of candidacy. The petition and affidavit shall be substantially in the form prescribed by the State Commissioner of Elections, shall include information required by the Code of Iowa, and shall be signed in accordance with the Code of Iowa.

(Code of Iowa, Sec. 45.3, 45.5 & 45.6)

#### 1.15.05 FILING, PRESUMPTION, WITHDRAWALS, OBJECTIONS.

The time and place of filing nomination petitions, the presumption of validity thereof, the right of a candidate so nominated to withdraw and the effect of such withdrawal, and the right to object to the legal sufficiency of such petitions, or to the eligibility of the candidate, shall be governed by the appropriate provisions of Chapter 44 of the Code of Iowa.

(Code of Iowa, Sec. 45.4)

#### 1.15.06 PERSONS ELECTED.

The candidates who receive the greatest number of votes for each office on the ballot are elected, to the extent necessary to fill the positions open.

(Code of Iowa, Sec. 376.8[3])

**SECTION FOUR. REPEALER.** All other ordinances or parts of ordinances in conflict with the provisions of this ordinance are hereby repealed.

**SECTION FIVE. SEVERABILITY.** If any section, provision or part of this ordinance shall be adjudged invalid or unconstitutional, such adjudication shall not affect the validity of the ordinance as a whole or any section, provision, or part thereof not adjudged invalid or unconstitutional.

**SECTION SIX. WHEN EFFECTIVE.** This ordinance shall be in effect from and after its final passage, approval, and publication as provided by law.

**RESOLUTION NO. 5-18**

**INITIAL PASSAGE** this 4<sup>th</sup> day of January, 2018.

CITY OF KEOKUK, LEE COUNTY, IOWA

BY: \_\_\_\_\_  
THOMAS L. RICHARDSON, MAYOR

ATTEST: \_\_\_\_\_  
JEAN LUDWIG, CITY CLERK

ROLL CALL: O’CONNOR – AYE MOORE – ABSENT PAYNE – AYE DADE –  
AYE HELENTHAL – ABSENT MORTIMER – AYE GREENWALD – AYE  
BRYANT – AYE DUNEK – NAY

AYES – 6

NAYS – 1

ABSENT – 2

**RESOLUTION NO. 7-18**

**SECOND PASSAGE** this 18<sup>th</sup> day of January, 2018.

CITY OF KEOKUK, LEE COUNTY, IOWA

BY: \_\_\_\_\_  
THOMAS L. RICHARDSON, MAYOR

ATTEST: \_\_\_\_\_  
JEAN LUDWIG, CITY CLERK

ROLL CALL: O’CONNOR – ABSENT MOORE – ABSENT PAYNE – AYE  
DADE – AYE HELENTHAL – AYE MORTIMER – AYE GREENWALD – AYE  
BRYANT – AYE DUNEK – ABSENT

AYES – 6

NAYS – 0

ABSENT – 3

**RESOLUTION NO.**

**FINAL PASSAGE** this 1<sup>st</sup> day of February, 2018.

CITY OF KEOKUK, LEE COUNTY, IOWA

BY: \_\_\_\_\_  
THOMAS L. RICHARDSON, MAYOR

ATTEST: \_\_\_\_\_  
JEAN LUDWIG, CITY CLERK

ROLL CALL: O'CONNOR – MOORE – PAYNE – DADE – HELENTHAL  
MORTIMER – GREENWALD – BRYANT – DUNEK –

AYES –

NAYS –

ABSENT –

Passed this 1<sup>st</sup> day of February, 2018.

CITY OF KEOKUK, LEE COUNTY, IOWA

By: \_\_\_\_\_  
THOMAS L. RICHARDSON

ATTEST:

I, Jean Ludwig, City Clerk of the City of Keokuk, hereby certify that that the above and foregoing is a true copy of an ordinance, passed by the City Council of said City at a meeting held on February 1, 2018.

\_\_\_\_\_  
JEAN LUDWIG, CITY CLERK

**RESOLUTION NO.**

A RESOLUTION APPROVING THE INITIAL READING OF ORDINANCE 1981.

**BE IT HEREBY RESOLVED BY THE CITY COUNCIL OF THE CITY OF KEOKUK, IOWA:**

**THAT**, the Keokuk City Council approves the initial reading of Ordinance No. 1981 Amending Title 13 Chapter 8, "Sewer Rates", of the Keokuk Municipal Code.

MOVED BY:

SECONDED BY:

Passed this 1<sup>st</sup> day of February, 2018.

ROLL CALL:

AYES –

NAYS –

ABSENT –

\_\_\_\_\_  
THOMAS L. RICHARDSON, MAYOR

ATTEST:

\_\_\_\_\_  
JEAN LUDWIG, CITY CLERK

## **ORDINANCE NO. 1981**

### **AN ORDINANCE AMENDING TITLE 13 CHAPTER 8, "SEWER RATES," OF THE KEOKUK MUNICIPAL CODE**

#### **BE IT ORDAINED BY THE CITY COUNCIL OF THE CITY OF KEOKUK, LEE COUNTY, IOWA:**

**Section 1.** Section 13.08.040, Class I Rates, is amended to read as follows:  
Rates for class I users shall be calculated on the total contribution of CBOD, TSS and flow.

Effective for all bills issued after July 1, 2018, Rates for class I users are as follows:

- (1) Flow, Five thousand forty seven dollars (\$5325) per million gallons;
- (2) CBOD, \$0.207 per pound;
- (3) TSS, \$0.202 per pound.

**Section 2.** Section 13.08.060, Class II Rates, is amended to read as follows:  
Effective for all bills issued after July 1, 2018, Rates for the class II users shall be \$ 6.69 per unit per month on usage over the minimum rate allowance based on actual or estimated monthly water meter readings. The minimum monthly rate for class II users shall be twenty eight dollars and eighty cents (\$30.38) based on two units. For this section, units shall be considered 750 gallons of water.

**Section 3.** This ordinance shall be in effect from and after its final passage, approval, and publication, as provided by law.

**RESOLUTION NO.**

**INITIAL PASSAGE** this 1<sup>st</sup> day of February, 2018.

CITY OF KEOKUK, LEE COUNTY, IOWA

BY: \_\_\_\_\_  
THOMAS L. RICHARDSON, MAYOR

ATTEST: \_\_\_\_\_  
JEAN LUDWIG, CITY CLERK

ROLL CALL: O'CONNOR – MOORE – PAYNE – DADE –  
HELENTHAL – MORTIMER – GREENWALD – BRYANT –  
DUNEK –

AYES – NAYS – ABSENT –

**RESOLUTION NO.**

**SECOND PASSAGE** this \_\_\_ day of \_\_\_\_\_, 2018.

CITY OF KEOKUK, LEE COUNTY, IOWA

BY: \_\_\_\_\_  
THOMAS L. RICHARDSON, MAYOR

ATTEST: \_\_\_\_\_  
JEAN LUDWIG, CITY CLERK

ROLL CALL: O'CONNOR – MOORE – PAYNE – DADE –  
HELENTHAL – MORTIMER – GREENWALD –  
BRYANT – DUNEK –

AYES – NAYS – ABSENT –

**RESOLUTION NO.**

**FINAL PASSAGE** this \_\_\_\_ day of \_\_\_\_\_, 2018.

CITY OF KEOKUK, LEE COUNTY, IOWA

BY: \_\_\_\_\_  
THOMAS L. RICHARDSON, MAYOR

ATTEST: \_\_\_\_\_  
JEAN LUDWIG, CITY CLERK

ROLL CALL: O'CONNOR – MOORE – PAYNE – DADE –  
HELENTHAL – MORTIMER – GREENWALD – BRYANT  
DUNEK –

AYES – NAYS – ABSENT –

Passed this 1<sup>st</sup> day of February, 2018.

CITY OF KEOKUK, LEE COUNTY, IOWA

By: \_\_\_\_\_  
THOMAS L. RICHARDSON, MAYOR

ATTEST:

I, Jean Ludwig, City Clerk of the City of Keokuk, hereby certify that that the above and foregoing is a true copy of an ordinance, passed by the City Council of said City at a meeting held on February 1, 2018.

\_\_\_\_\_  
JEAN LUDWIG, CITY CLERK

# Commercial Firm Quote

Quote Name: Keokuk WPCP

Quote Number: 127914

Date: December 18, 2017

## 1. Bidder's Contact Information

|                           |                            |
|---------------------------|----------------------------|
| Company Name              | WesTech Engineering, Inc.  |
| Contact Name              | David Mortensen            |
| Phone                     | 801.265.1000               |
| Email                     | dmortensen@westech-inc.com |
| Address: Number/Street    | 3665 South West Temple     |
| Address: City, State, Zip | Salt Lake City, UT 84115   |

## 2. Pricing

|          |            |
|----------|------------|
| Currency | US Dollars |
|----------|------------|

### Scope of Supply

|   |             |
|---|-------------|
| Item A – One (1) Retrofit 42 Cage Drive for Envirex® H40LT Cage Drive | \$42,043.00 |
|---|-------------|

Prices are for a period not to exceed 30 days from date of proposal.

### Additional Field Service

|   |             |
|---|-------------|
| Daily Rate – First Day (includes travel time, air fare, and traveling expenses) | \$ 4,215.00 |
|---|-------------|

|   |             |
|---|-------------|
| Daily Rate – Additional Days in the Same Trip | \$ 1,235.00 |
|---|-------------|

Field services are to provide advisory supervision of installation, inspection of installation, or equipment start up services. Field service prices include travel expenses. A field service day is billed for any 8-hour day, or any portion thereof. Overtime time hours are billed at \$180.00 per hour. Any travel or labor required on weekend (Saturday or Sunday) days or WesTech recognized holidays will incur additional charges. Any canceled charges due to the customer's request will be added to the invoice. A two week notice is required prior to trip departure date.

|  |              |
|--|--------------|
| Taxes (sales, use, VAT, IVA, IGV, duties, import fees, etc.) | Not Included |
|--|--------------|

## 3. Payment Terms

|                                |      |
|--------------------------------|------|
| Net due 30 days after shipment | 100% |
|--------------------------------|------|

All payments are net 30 days. Partial shipments are allowed. Other terms per WesTech proforma invoice.

## 4. Schedule

The estimated time to shipment is 14 to 16 weeks after WesTech has received approved submittals from the purchaser.

**WESTECH**

Quote No. 127914

## 5. Freight

|                    |                           |                                       |
|--------------------|---------------------------|---------------------------------------|
| <b>Terms</b>       |                           | FOB at Job Site, Full Freight Allowed |
| <b>From</b>        | <b>Final Destination</b>  | <b>Conveyance</b>                     |
| Salt Lake City, UT | Keokuk WPCP<br>Keokuk, IA | Flat Bed Truck                        |

**WesTech drive units are delivered to the job site as a single, completely assembled and shop-tested unit, ready to be installed on the clarifier center column. The result of a thorough design and meticulous component selection is a strong, reliable, high-quality drive that will provide a long service life with minimum maintenance.**

### **Direct Coupling**

Direct coupling of motor, reducer, and pinion shaft eliminates chain or belt drive transmissions, thus increasing efficiency and operator safety. This arrangement also allows for direct and accurate torque monitoring with WesTech's Torkmatic™ torque control.

### **Electric Motor**

The electric motor, direct coupled to a speed reducer, rotates the internal gear by means of a pinion fastened to the output shaft of the speed reducer. The drive control pointer indicates the torque loading in percentages. The electric motor is totally enclosed, suitable for outdoor service, but other commercially available motors to suit environment or service, such as explosion proof, can be furnished. When required, a variable speed drive can be added to vary the output speed of the drive. This allows optimization of the process, which can result in long term savings.

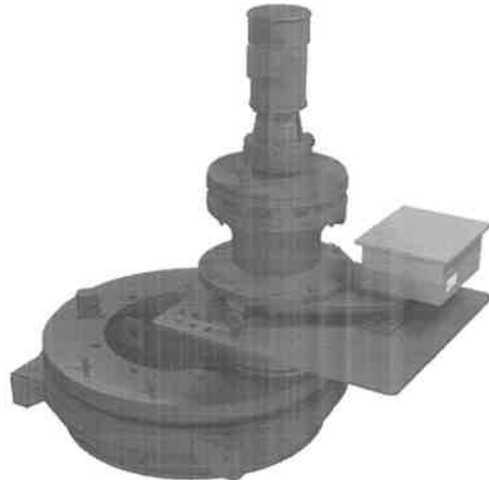

### **Input Speed Reducer**

The speed reducer, driven by the motor, is a completely sealed oil or grease lubricated unit. It is of the cycloidal type, which combines extremely high ratios with high efficiency and low wear in a compact unit. Torque transmitting elements roll rather than grinding or sliding, thus achieving efficiencies of 90 percent. Virtually no wear failures have occurred in properly sized Westech drives. Even after 30 years of operation, many WesTech reducers are still in use.

### **Torkmatic™ Drive Control**

The Torkmatic™ torque control indicates and senses the output torque of the drive main gear. At excessively high torques, an alarm will sound or the motor will stop, thus protecting the drive unit and mechanism. The torque control mechanism is extremely accurate at reading torque and is housed in a

NEMA 4X weatherproof enclosure. The torque control can be equipped with a 4-20 mA signal output for customer convenience and monitoring of the process from a remote location.

### **Precision Bearing Advantages**

#### **Precision Manufacturing Tolerances**

The bearings utilized are acceptable for high load, high speed applications and are manufactured by recognized bearing companies. The use of these precision bearings is widespread among larger and more heavily loaded clarifier and thickener mechanisms common to the metallurgical industries.

#### **Exceptional long life and load capacities**

Instead of applying the bearing load in four points on the bearing balls as with old-style strip lined bearings, the precision bearing utilizes a full band contact race with hardness equal to that of the strip liners. Calculated bearing life is at least five times that for strip liners of the same ball size and diameter. The need for splitting gears and housings is eliminated because of the superior service life.

#### **Overturning Load Capacity**

Strip lined bearings have no inherent overturning load capacity and must rely on the mechanism weight alone to hold the bearing race together. This capacity of the precision bearing makes possible tank settling, misalignment, and lack of precision leveling of the drive during installation and operation a far less determining factor in premature bearing failure.

#### **Main Bearing Protection**

WesTech gear housings protect from dirt and contamination using designed neoprene seals and gaskets, whereas strip lined bearings can only use a loose felt seal. WesTech precision gears also allow the bearing to run in a separate sealed grease cavity, which achieves additional protection from contamination.

# Terms & Conditions

Terms and Conditions appearing in any order based on this proposal which are inconsistent herewith shall not be binding on WesTech Engineering Inc. The sale and purchase of equipment described herein shall be governed exclusively by the foregoing proposal and the following provisions:

1. **Specifications:** WesTech Engineering Inc. is furnishing its standard equipment as outlined in the proposal and as will be covered by final approved drawings. The equipment may not be in strict compliance with the Engineer's/Owner's plans, specifications, or addenda as there may be deviations. The equipment will, however, meet the general intention of the mechanical specifications of these documents.
2. **Items Included:** This proposal includes only the equipment specified herein and does not include erection, installation, accessories, nor associated materials such as controls, piping, etc., unless specifically listed.
3. **Parties to Contract:** WesTech Engineering Inc. is not a party to or bound by the terms of any contract between WesTech Engineering Inc.'s customer and any other party. WesTech Engineering Inc.'s undertakings are limited to those defined in the contract between WesTech Engineering Inc. and its direct customers.
4. **Price and Delivery:** All selling prices quoted are subject to change without notice after 30 days from the date of this proposal unless specified otherwise. Unless otherwise stated, all prices are F.O.B. WesTech Engineering Inc. or its supplier's shipping points. All claims for damage, delay or shortage arising from such equipment shall be made by Purchaser directly against the carrier. When shipments are quoted F.O.B. job site or other designation, Purchaser shall inspect the equipment shipped, notifying WesTech Engineering Inc. of any damage or shortage within forty-eight hours of receipt, and failure to so notify WesTech Engineering Inc. shall constitute acceptance by Purchaser, relieving WesTech Engineering Inc. of any liability for shipping damages or shortages.
5. **Payments:** All invoices are net 30 days. Delinquencies are subject to a 1.5 percent service charge per month or the maximum permitted by law, whichever is less on all past due accounts. Pro rata payments are due as shipments are made. If shipments are delayed by the Purchaser, invoices shall be sent on the date when WesTech Engineering Inc. is prepared to make shipment and payment shall become due under standard invoicing terms. If the work to be performed hereunder is delayed by the Purchaser, payments shall be based on the purchase price and percentage of completion. Products held for the Purchaser shall be at the risk and expense of the Purchaser. Unless specifically stated otherwise, prices quoted are for equipment only. These terms are independent of and not contingent upon the time and manner in which the Purchaser receives payment from the owner.
6. **Payment Terms:** Credit is subject to acceptance by WesTech Engineering Inc.'s Credit Department. If the financial condition of the Purchaser at any time is such as to give WesTech Engineering Inc., in its judgment, doubt concerning the Purchaser's ability to pay, WesTech Engineering Inc. may require full or partial payment in advance or may suspend any further deliveries or continuance of the work to be performed by the WesTech Engineering Inc. until such payment has been received.
7. **Escalation:** If shipment is, for any reason, deferred by the Purchaser beyond the normal shipment date, or if material price increases are greater than 5% from proposal date to material procurement date, stated prices set forth herein are subject to escalation. The escalation shall be based upon increases in labor and material and other costs to WesTech Engineering Inc. that occur in the time period between quotation and shipment by WesTech Engineering Inc. Purchaser agrees to this potential escalation regardless of contradicting terms in the contract, except when an agreed upon escalation adder is included in the price.
  - (a) The total quoted revised price is based upon changes in the indices published by the United States Department of Labor, Bureau of Labor Statistics. Labor will be related to the Average Hourly Earnings indices found in the Employment and Earnings publication.

Material will be related to the Metal and Metal Products Indices published in Wholesale Prices and Prices Indices.

- (b) Price revision for items furnished to, and not manufactured by WesTech Engineering Inc., which exceed the above escalation calculation, will be passed along by WesTech Engineering Inc. to Purchaser based upon the actual increase in price to WesTech Engineering Inc. for the period from the date of quotation to the date of shipment by WesTech Engineering Inc. Any item that is so revised will be excluded from the index escalation calculations set forth in subparagraph (a) above.
8. **Approval:** If approval of equipment submittals by Purchaser or others is required, a condition precedent to WesTech Engineering Inc. supplying any equipment shall be such complete approval.
9. **Installation Supervision:** Prices quoted for equipment do not include installation supervision. WesTech Engineering Inc. recommends and will, upon request, make available, at WesTech Engineering Inc.'s then current rate, an experienced installation supervisor to act as the Purchaser's employee and agent to supervise installation of the equipment. Purchaser shall at its sole expense furnish all necessary labor equipment, and materials needed for installation.

Responsibility for proper operation of equipment, if not installed by WesTech Engineering Inc. or installed in accordance with WesTech Engineering Inc.'s instructions, and inspected and accepted in writing by WesTech Engineering Inc., rests entirely with Purchaser; and any work performed by WesTech Engineering Inc. personnel in making adjustment or changes must be paid for at WesTech Engineering Inc.'s then current per diem rates plus living and traveling expenses.
- WesTech Engineering Inc. will supply the safety devices described in this proposal or shown in WesTech Engineering Inc.'s drawings furnished as part of this order but excepting these, WesTech Engineering Inc. shall not be required to supply or install any safety devices whether required by law or otherwise. The Purchaser hereby agrees to indemnify and hold harmless WesTech Engineering Inc. from any claims or losses arising due to alleged or actual insufficiency or inadequacy of the safety devices offered or supplied hereunder, whether specified by WesTech Engineering Inc. or Purchaser, and from any damage resulting from the use of the equipment supplied hereunder.
10. **Acceptance of Products:** Products will be deemed accepted without any claim by Purchaser unless written notice of non-acceptance is received by WesTech Engineering Inc. within 30 days of delivery if shipped F.O.B. point of shipment, or 48 hours of delivery if shipped F.O.B. point of destination. Such written notice shall not be considered received by WesTech Engineering Inc. unless it is accompanied by all freight bills for said shipment, with Purchaser's notations as to damages, shortages and conditions of equipment, containers, and seals. Non-accepted products are subject to the return policy stated below.
11. **Taxes:** Any federal, state, or local sales, use or other taxes applicable to this transaction, unless specifically included in the price, shall be for Purchaser's account.
12. **Title:** The equipment specified herein, and any replacements or substitutes therefore shall, regardless of the manner in which affixed to or used in connection with realty, remain the sole and personal property of WesTech Engineering Inc. until the full purchase price has been paid. Purchaser agrees to do all things necessary to protect and maintain WesTech Engineering Inc.'s title and interest in and to such equipment; and upon Purchaser's default, WesTech Engineering Inc. may retain as liquidated damages any and all partial payments made and shall be free to enter the premises where such equipment is located and remove the same as its property without prejudice to any further claims on account of damages or loss which WesTech Engineering Inc. may suffer from any cause.
13. **Insurance:** From date of shipment until the invoice is paid in full, Purchaser agrees to provide and maintain at its expense, but for WesTech Engineering Inc.'s benefit, adequate

insurance including, but not limited to, builders risk insurance on the equipment against any loss of any nature whatsoever.

**14. Shipments:** Any shipment or delivery dates recited represent WesTech Engineering Inc.'s best estimate but no liability, direct or indirect, is assumed by WesTech Engineering Inc. for failure to ship or deliver on such dates.

WesTech Engineering Inc. shall have the right to make partial shipments; and invoices covering the same shall be due and payable by Purchaser in accordance with the payment terms thereof. If Purchaser defaults in any payment when due hereunder, WesTech Engineering Inc. may, without incurring any liability therefore to Purchaser or Purchaser's customers, declare all payments immediately due and payable with maximum legal interest thereon from due date of said payment, and at its option, stop all further work and shipments until all past due payments have been made, and/or require that any further deliveries be paid for prior to shipment.

If Purchaser requests postponements of shipments, the purchase price shall be due and payable upon notice from WesTech Engineering Inc. that the equipment is ready for shipment; and thereafter any storage or other charge WesTech Engineering Inc. incurs on account of the equipment shall be for the Purchaser's account.

If delivery is specified at a point other than WesTech Engineering Inc. or its supplier's shipping points, and delivery is postponed or prevented by strike, accident, embargo, or other cause beyond WesTech Engineering Inc.'s reasonable control and occurring at a location other than WesTech Engineering Inc. or its supplier's shipping points, WesTech Engineering Inc. assumes no liability in delivery delay. If Purchaser refuses such delivery, WesTech Engineering Inc. may store the equipment at Purchaser's expense. For all purposes of this agreement such tender of delivery or storage shall constitute delivery.

**15. Warranty:** WESTECH ENGINEERING INC. WARRANTS EQUIPMENT IT SUPPLIES ONLY IN ACCORDANCE WITH THE WARRANTY EXPRESSED IN THE ATTACHED COPY OF "WESTECH WARRANTY" AGAINST DEFECTS IN WORKMANSHIP AND MATERIALS WHICH IS MADE A PART HEREOF. SUCH WARRANTY IN LIEU OF ALL OTHER WARRANTIES, INCLUDING WARRANTIES OF MERCHANTABILITY AND FITNESS FOR PARTICULAR PURPOSE, WHETHER WRITTEN, ORAL, EXPRESSED, IMPLIED OR STATUTORY, WESTECH ENGINEERING INC. SHALL NOT BE LIABLE ANY CONTINGENT, INCIDENTAL, OR CONSEQUENTIAL DAMAGES FOR ANY REASON WHATSOEVER.

**16. Patents:** WesTech Engineering Inc. agrees that it will, at its own expense, defend all suits or proceedings instituted against Purchaser and pay any award of damages assessed against it in such suits or proceedings, so far as the same are based on any claim that the said equipment or any part thereof constitutes an infringement of any apparatus patent of the United States issued at the date of this Agreement, provided WesTech Engineering Inc. is given prompt notice in writing of the institution or threatened institution of any suit or proceeding and is given full control of the defense, settlement, or compromise of any such action; and Purchaser agrees to give WesTech Engineering Inc. needed information, assistance, and authority to enable WesTech Engineering Inc. to do. In the event said equipment is held or conceded to infringe such a patent, WesTech Engineering Inc. shall have the right at its sole option and expense to a) modify the equipment to be non-infringing, b) obtain for Purchaser the license to continue using said equipment, or c) accept return of the equipment and refund to the Purchaser the purchase price thereof less a reasonable charge for the use thereof. WesTech Engineering Inc. will reimburse Purchaser for actual out-of-pocket expenses, exclusive of legal fees, incurred in preparing such information and rendering such assistance at WesTech Engineering Inc.'s request. The foregoing states the entire liability of WesTech Engineering Inc., with respect to patent infringement; and except as otherwise agreed to in writing, WesTech Engineering Inc. assumes no responsibility for process patent infringement.

**17. Surface Preparation and Painting:** If furnished, shop primer paint is intended to serve only as minimal protective finish. WesTech Engineering Inc. will not be responsible for the condition of primed or finish painted surfaces after equipment leaves its shops. Purchasers are invited to inspect paint in shops for proper preparation and application prior to shipment. WesTech Engineering Inc. assumes no responsibility for field surface preparation or touch-up of shipping damage to paint. Painting of fasteners and other touch-up to painted surfaces will be by Purchaser's painting contractor after mechanism installation.

Motors, gear motors, and other components not manufactured by WesTech Engineering Inc. will be painted with that manufacturer's standard paint system. It is WesTech Engineering Inc.'s intention to ship major steel components as soon as fabricated, often before drive, motors, and other manufactured components. Unless Purchaser can ensure that shop primed steel shall be field painted within thirty (30) days after arrival at the job site, WesTech Engineering Inc. encourages the Purchaser to order these components without primer.

WesTech Engineering Inc.'s prices are based on paints and surface preparations as outlined in the main body of this proposal. In the event that an alternate paint system is selected, WesTech Engineering Inc. requests that Purchaser's order advise of the paint selection. WesTech Engineering Inc. will then either adjust the price as may be necessary to comply or ship the material unpainted if compliance is not possible due to application problems or environmental controls.

**18. Cancellation, Suspension, or Delay:** After acceptance by WesTech Engineering Inc., this proposal, or Purchaser's order based on this proposal, shall be a firm agreement and is not subject to cancellation, suspension, or delay except upon payment by Purchaser of appropriate charges which shall include all costs incurred by WesTech Engineering Inc. to date of cancellation, suspension, or delay plus a reasonable profit. Additionally, all charges related to storage and/or resumption of work, at WesTech Engineering Inc.'s plant or elsewhere, shall be for Purchaser's sole account; and all risks incidental to storage shall be assumed by Purchaser.

**19. Return of Products:** No products may be returned to WesTech Engineering Inc. without WesTech Engineering Inc.'s prior written permission. Said permission may be withheld by WesTech Engineering Inc. at its sole discretion.

**20. Backcharges:** WesTech Engineering Inc. will not approve or accept backcharges for labor, materials, or other costs incurred by Purchaser or others in modification, adjustment, service, or repair of WesTech Engineering Inc.-furnished materials unless such back charge has been authorized in advance in writing by a WesTech Engineering Inc. employee, by a WesTech Engineering Inc. purchase order, or work requisition signed by WesTech Engineering Inc.

**21. Indemnification:** Purchaser agrees to indemnify WesTech Engineering Inc. from all costs incurred, including but not limited to court costs and reasonable attorney fees, from enforcing any provisions of this contract, including but not limited to breach of contract or costs incurred in collecting monies owed on this contract.

**22. Entire Agreement:** This proposal expresses the entire agreement between the parties hereto superseding any prior understandings, and is not subject to modification except by a writing signed by an authorized officer of each party.

**23. Motors and Motor Drives:** In order to avoid shipment delays of WesTech Engineering Inc. equipment, the motor drives may be sent directly to the job site for installation by the equipment installer. Minor fit-up may be required.

**24. Extended Storage:** Extended storage instructions will be part of information provided to shipment. If equipment installation and start-up is delayed more than 30 days, the provisions of the storage instructions must be followed to keep WARRANTY in force.

**25. Liability:** Professional liability insurance, including but not limited to, errors and omissions insurance, is not included. In any event, liability for errors and omissions shall be limited to the lesser of \$100,000USD or the value of the particular piece of equipment (not the value of the entire order) supplied by WesTech Engineering Inc. against which a claim is sought.

**26. Arbitration Negotiation:** Any controversy or claim arising out of or relating to the performance of any contract resulting from this proposal or contract issued, or the breach thereof, shall be settled by arbitration in accordance with the Construction Industry Arbitration Rules of the American Arbitration Association, and judgment upon the award rendered by the arbitrator(s) may be entered to any court having jurisdiction.

ACCEPTED BY PURCHASER

Customer Name: \_\_\_\_\_

Customer Address: \_\_\_\_\_

\_\_\_\_\_

\_\_\_\_\_

Contact Name: \_\_\_\_\_

Contact Phone: \_\_\_\_\_

Contact Email: \_\_\_\_\_

Signature: \_\_\_\_\_

Printed Name: \_\_\_\_\_

Title: \_\_\_\_\_

Date: \_\_\_\_\_

**RESOLUTION NO.**

**A RESOLUTION AUTHORIZING THE DISPOSAL OF SURPLUS CITY PROPERTY IN THE FORM OF A 2000 PIERCE SABER RESCUE PUMPER**

**WHEREAS**, the City of Keokuk is the current owner of certain property described as a 2000 Pierce Saber Rescue Pumper, 500 Gallon, VIN 4P1CT02UOYA000052; and

**WHEREAS**, the City of Keokuk Corporate Authorities hereby find that this property is no longer necessary or useful to, nor for the best interest of the City of Keokuk to retain ownership of the personal property herein described, and is therefore considered surplus property; and

**WHEREAS**, it has been determine by the City of Keokuk that this property should be sold to another Iowa Fire Department for their use; and

**WHEREAS**, the Jackson Township Fire Association, with its principal place of business at 3640 Argyle Road, Keokuk, Iowa 52632, has offered to purchase the afore described property for \$25,000.00;

**BE IT IS HEREBY RESOLVED BY THE CITY COUNCIL OF THE CITY OF KEOKUK, LEE COUNTY, IOWA**, that:

**Section One:**

The foregoing recitals are hereby incorporated as findings of fact.

**Section Two:**

The Mayor is hereby authorized and directed to sign any and all necessary documents, including the Used Equipment Sales Agreement, hereto attached, and further authorized and directed to utilize all necessary staff to effectuate the sale of the afore-described 2000 Pierce Saber Rescue Pumper to the Jackson Township Fire Association for \$25,000.00.

Passed this 1<sup>st</sup> day of February, 2018.

CITY OF KEOKUK, LEE COUNTY, IOWA

By: \_\_\_\_\_  
THOMAS L. RICHARDSON, MAYOR

ATTEST: \_\_\_\_\_  
JEAN LUDWIG, CITY CLERK